

Safe Driver Program

Handbook EL-804

February 2013
Transmittal Letter

A. Explanation

The purpose of this handbook is to establish policy and provide guidelines to ensure that Postal Service™ drivers are screened, trained, and qualified to drive safely. It is addressed to all Postal Service employees who manage, supervise, train, and test individuals who will be awarded driving privileges or currently have driving privileges. By following the procedures in this guide, stakeholders will ensure that drivers are trained to integrate safe driving practices into their daily activities.

B. Distribution and Requisition

This handbook is available on the Postal Service PolicyNet Web site: <http://blue.usps.gov/cpim>.

C. Comments

Comments and questions about the content of this document can be submitted in writing to:

SAFETY AND HEALTH
US POSTAL SERVICE
475 L'ENFANT PLZ SW RM 9801
WASHINGTON DC 20260-4261

D. Effective Date

This handbook is effective January 15, 2013.

*Linda DeCarlo, Director
Safety and Health
Employee Resource Management*

Contents

| | | |
|----------|--|-----------|
| 1 | Introduction..... | 1 |
| 11 | Preventing and Reducing Motor Vehicle Accidents..... | 1 |
| 111 | Purpose..... | 1 |
| 112 | Objectives..... | 1 |
| 12 | Definitions and Acronyms..... | 1 |
| 121 | Definitions..... | 1 |
| 122 | Acronyms..... | 4 |
| 13 | Program Administration..... | 4 |
| 131 | Manager, Safety (Area)..... | 5 |
| 132 | Manager, Human Resources (District)..... | 5 |
| 133 | Manager, Learning, Development and Diversity (District)..... | 5 |
| 134 | Manager, Safety (District)..... | 5 |
| 135 | Driving Safety Instructors..... | 5 |
| 136 | On-the-Job Instructors..... | 5 |
| 14 | Program Supervision..... | 6 |
| 141 | Observation of Driving Practices..... | 6 |
| 142 | Responsibilities..... | 6 |
| 143 | Learning to Observe Drivers..... | 7 |
| 144 | Evaluating Probationary Employees..... | 7 |
| 145 | PS Form 4582 – Operator’s Record..... | 8 |
| 15 | Drivers’ Responsibilities..... | 8 |
| 151 | General Principles..... | 8 |
| 152 | References..... | 9 |
| 2 | Screening and Selecting Drivers..... | 11 |
| 21 | Importance of Proper Screening and Selection..... | 11 |
| 211 | Postal Service Policy..... | 11 |
| 212 | Responsibility for Screening..... | 11 |
| 213 | Determination of Eligible and Qualified..... | 11 |
| 214 | Determination of Suitable..... | 11 |
| 215 | Human Resources Responsibilities..... | 11 |
| 22 | Reviewing Driving Record..... | 12 |
| 221 | Appointing Official’s Responsibilities..... | 12 |
| 222 | Interpreting Driving History..... | 12 |
| 223 | Resolving Discrepancies..... | 12 |
| 224 | Applicant’s Responsibility..... | 13 |
| 225 | Employees Who Request Reassignment..... | 13 |

| | | |
|----------|---|-----------|
| 226 | Military Personnel | 13 |
| 23 | Medical Suitability for a Position Requiring Operation of a Motor Vehicle as an Official Duty | 13 |
| 231 | Medical Assessment | 13 |
| 232 | Responsibility for Medical Assessment | 14 |
| 233 | Medical and Vision Requirements for Maintaining Driving Privileges | 14 |
| 3 | Training Drivers | 17 |
| 31 | Introduction | 17 |
| 311 | Philosophy of Driver Training | 17 |
| 312 | Goal and Objectives | 17 |
| 313 | Types of Driver Training | 17 |
| 32 | Administration | 17 |
| 321 | Satellite Sites | 17 |
| 322 | Lighting | 18 |
| 323 | Documentation | 18 |
| 324 | Selecting Vehicles | 18 |
| 33 | Driver Training | 18 |
| 331 | Components | 18 |
| 332 | Incidental Drivers and Non-driving Employees | 20 |
| 333 | Training Requirements for Driving Employees With Breaks in Service | 21 |
| 334 | Web-based Driver Training | 22 |
| 335 | Vehicle Familiarization | 22 |
| 336 | Controlled Driving — Skills Courses and Street Drive | 23 |
| 337 | End-of-Training Certification | 26 |
| 34 | Refresher Driver Training | 27 |
| 341 | When to Conduct | 27 |
| 342 | Content | 27 |
| 35 | Driver Improvement Training | 28 |
| 351 | When to Conduct | 28 |
| 352 | Content | 28 |
| 353 | Documentation | 28 |
| 36 | Special Emphasis Vehicle Orientation | 28 |
| 361 | When to Conduct | 28 |
| 362 | Content | 29 |
| 363 | Documentation | 29 |
| 4 | State Driver’s Licenses | 31 |
| 41 | Requirements | 31 |
| 411 | Employees’ Responsibilities | 31 |
| 412 | Supervisors’ Responsibilities | 31 |

| | | |
|----------|--|-----------|
| 413 | Incidental Drivers and Non-driving Employees | 31 |
| 414 | Special Requirements for Operators With CDLs. | 31 |
| 42 | Suspension and Revocation of Driving Privileges | 32 |
| 421 | Reason for Suspension or Revocation | 32 |
| 422 | Temporary Suspension of Driving Privileges | 34 |
| 423 | Decision Criteria | 35 |
| 424 | Special Cases | 35 |
| 5 | Driving Safety Instructors | 37 |
| 51 | Duties and Responsibilities. | 37 |
| 52 | Selection, Training, and Certification | 37 |
| 521 | Selection | 37 |
| 522 | Training | 37 |
| 523 | Certification | 37 |
| 524 | Uniforms, Activity Codes, and Training. | 38 |
| 53 | Ad Hoc Driving Safety Instructors | 38 |
| 531 | Duties and Responsibilities. | 38 |
| 532 | Selection, Training, and Certification | 38 |
| | Appendix A – Mirror Adjustment Stations | 39 |
| | Appendix B – Controlled Driving Skills Course | 51 |
| | Appendix C – Delivery Skills Course | 57 |
| | Appendix D – Large-Truck Skills Course. | 77 |

This page intentionally left blank

Exhibits

| | |
|---|----|
| Exhibit 141 | |
| Observation of Driving Practices | 6 |
| Exhibit 233 | |
| Medical and Vision Requirements for Maintaining Driving Privileges for Postal-Owned or -Leased Vehicles According to Type of Vehicle | 14 |
| Exhibit 331 | |
| Right-Hand-Drive Privilege Certification Training | 18 |
| Exhibit 331.2 | |
| Safe Driver Program Training Matrix | 19 |
| Exhibit 333.2 | |
| Summary of Training Requirement | 21 |
| Exhibit 334.1 | |
| Web-based Driver Training | 22 |
| Exhibit 335.4 | |
| Drivers Required to Take Vehicle Familiarization | 23 |
| Exhibit 336.7 | |
| Drivers Required to Take Controlled Driving Training | 26 |
| Exhibit 337.3 | |
| Drivers Required to Obtain the RHD Privilege Certification | 27 |
| Exhibit 421.12 | |
| Procedures to Suspend or Revoke Postal Service Driving Privileges. | 33 |
| Exhibit A-1 | |
| Mirror Adjustment Station | 40 |
| Exhibit A-2.1 | |
| Mirror Adjustment Station 1 | 41 |
| Exhibit A-2.2 | |
| Mirror Adjustment Station 2 | 42 |
| Exhibit A-2.3 | |
| Mirror Adjustment Station 3 | 43 |
| Exhibit A-2.4 | |
| Mirror Adjustment Station | 44 |
| Exhibit A-2.5 | |
| Mirror Adjustment Station 5 | 45 |
| Exhibit A-2.6 | |
| Mirror Adjustment Station | 46 |
| Exhibit A-2.7 | |
| Mirror Adjustment Station 7 | 47 |

| | |
|--|----|
| Exhibit A-3.1 | |
| Mirror Adjustment Station: Activity 1 | 48 |
| Exhibit A-3.2 | |
| Mirror Adjustment Station: Activity 2 | 49 |
| Exhibit B-1 | |
| Postal Service Controlled Driving Skills Course | 52 |
| Exhibit B-2 | |
| Equipment Needed for Skills Courses (required and optional stations) | 53 |
| Exhibit C-1.1 | |
| Intersection Station: Task 1 | 58 |
| Exhibit C-1.2 | |
| Intersection Station: Task 2 | 59 |
| Exhibit C-1.3 | |
| Intersection Station: Task 3 | 60 |
| Exhibit C-1.4 | |
| Intersection Station: Task 4 | 61 |
| Exhibit C-1.5 | |
| Intersection Station: Task 5 | 62 |
| Exhibit C-1.6 | |
| Intersection Station: Task 6 | 63 |
| Exhibit C-2 | |
| Offset Backing Station | 64 |
| Exhibit C-3 | |
| Angled-Right-Turn Station | 65 |
| Exhibit C-4 | |
| U-Turn and 3-Point Turn Station (Optional) | 66 |
| Exhibit C-5 | |
| Parallel Parking Station | 67 |
| Exhibit C-6 | |
| In-Lane Driving Station (Optional) | 68 |
| Exhibit C-7.1 | |
| Curbside Delivery: Task 1 | 69 |
| Exhibit C-7.2 | |
| Curbside Delivery: Task 2 | 70 |
| Exhibit C-7.3 | |
| Curbside Delivery: Task 3 | 71 |
| Exhibit C-7.4 | |
| Curbside Delivery: Task 4 | 72 |
| Exhibit C-7.5 | |
| Curbside Delivery: Task 5 | 73 |
| Exhibit C-7.6 | |
| Curbside Delivery: Task 6 | 74 |
| Exhibit C-7.7 | |
| Curbside Delivery: Task 7 | 75 |

Exhibits

Exhibit D-1
Rear-Swing Clearance Station 78

Exhibit D-2
Forward, Stop, Straight-Line Backing Station 79

Exhibit D-3
Offset Backing Station 80

Exhibit D-4
Alley and Dock Backing Station 81

Exhibit D-5
Parallel Parking Station 82

This page intentionally left blank

1 Introduction

11 Preventing and Reducing Motor Vehicle Accidents

The key to reducing and preventing motor vehicle accidents is the proper and qualitative screening, selection, certification, and granting of driving privileges to drivers.

111 Purpose

The purpose of this handbook is to establish policy and provide guidelines to ensure that Postal Service™ drivers are screened, trained, and qualified to drive safely.

Drivers trained to integrate safe driving practices into their daily activities support the operational effectiveness of the Postal Service.

112 Objectives

The objectives of the safe driver program are to equip drivers to:

- a. Drive safely.
- b. Comply with Department of Transportation regulations.
- c. Reduce human suffering.
- d. Reduce property damage and costs.

12 Definitions and Acronyms

121 Definitions

For the purposes of this handbook, the following definitions apply:

At-Fault Accident. An accident in which:

- The driver's actions, or failure to act, were the primary or equally contributory cause of the accident; or
- The driver received a citation, fine, or adverse judgment.

Ad Hoc Driving Safety Instructor. A Postal Service employee who performs the duties of a Driving Safety Instructor on a part-time, as-needed basis.

Commercial Motor Vehicle. A motor vehicle having a gross vehicle weight rating (GVWR) of 10,001 or more pounds and used in commerce to transport passengers or property.

Controlled Driving. Training that comprises a skills course and street practice driving.

Defensive Driving Course (DDC). Online training designed to provide Postal Service employees with information and techniques to prevent motor vehicle collisions and be safe, professional drivers.

Driving Safety Instructor (DSI). Conducts DDC Debrief (Course No. 43601-06-CL), vehicle familiarization, vehicle operator training, driver instructor training, and some types of refresher and driver improvement training. The DSI may recommend appropriate Web-based refresher and driver improvement training for drivers to complete at their duty stations. DSIs also observe driving practices and coach drivers.

Driving Abstract. The driving record maintained by a state motor vehicle agency of an individual licensed to operate a motor vehicle within that state. The driving abstract lists the individual driver's traffic convictions, suspensions, revocations, and accidents as well as restrictions placed on the license owner.

Flexible Fuel Vehicle (FFV). A right-hand-drive version of the Ford Explorer with an aluminum body built by Utilimaster Corp. The FFV can operate on gasoline or ethanol.

Improvement Driving Training. Training provided to improve specific driving practices of a driver after an at-fault vehicle accident or when an unsafe driving practice is observed.

Incidental Drivers. Postal Service employees (bargaining and nonbargaining), including postmasters, postmaster reliefs, managers, supervisors, and other administrative, technical, and clerical employees who:

- Hold positions that do not normally require regular driving; or
- Hold positions in which driving is incidental to their duties; and
- Operate only their personal vehicles or administrative passenger vehicles.

Initial Driver Training. Training provided to all new drivers.

Learning, Development and Diversity (LDD). The Postal Service department responsible for training, testing, and developing Postal Service employees.

Motor Vehicle. Any mechanically or electrically powered device upon which a person or property may be transported or drawn upon a land highway. In addition, a motor vehicle is:

- Not moved by human power.
- Not operated on rails.

Note: The load of a motor vehicle is considered part of the vehicle.

Vehicles not considered "motor vehicles" include:

- Vehicles operated on fixed rails.
- Powered industrial trucks as defined by OSHA Standard 1910.178.
- Bicycles, snowmobiles, airplanes, and similar human transporters.

Motor Vehicle Accident. Any accident involving a motor vehicle that:

- Is operated for official Postal Service business (no matter who owns the vehicle); and
- Results in death, injury, or property damage of 1 dollar or more (unless the vehicle is properly and legally parked).

The following factors are *not* considered in determining if a motor vehicle accident has occurred:

- Who was injured.
- What property was damaged (and to what extent).
- Where the accident occurred.
- Who was responsible.

Motor Vehicle Accident Frequency Rate. The number of motor vehicle accidents per million miles driven. The Postal Service calculates the rate as follows:

$$\frac{\text{Number of Motor Vehicle Accidents (X) 1,000,000 Miles}}{\text{(Divided by) Total Miles Driven}}$$

The term *total miles driven* refers to the total number of miles motor vehicles travel in the performance of official Postal Service business. (This includes the mileage of all vehicles used in the performance of official Postal Service business.) Installation heads, managers, and supervisors are responsible for ensuring that all mileage accrued in the performance of official business is captured and reported.

Non-preventable Accident. A motor vehicle accident in which the Postal Service driver did everything reasonable that could have been done to prevent the accident under the National Safety Council's Safe Driver Award Rules.

Note: This definition is used only for the purposes of determining eligibility in the National Safety Council's Safe Driver Award Program and is not to be used in any other context.

Not-at-Fault Accident. A motor vehicle accident in which the driver's actions were not the primary or equally contributory cause of the accident.

On-the-Job Instructors (OJIs). Individuals selected and trained to administer job training to employees at the job site.

Potential Driving Employee. Any Postal Service employee who:

- Does not have driving privileges for specific types of vehicles; and
- Seeks, through promotion or reassignment, a position that requires driving as part of its official duties.

Practice Route Driving (Street Drive). A 45-minute period of practice driving used to acclimate the examinee to the certification process.

Preventable Accident. A motor vehicle accident in which the driver failed to do everything that could reasonably have been done to prevent the accident under the National Safety Council's Safe Driver Award Rules.

Note: This definition is used only for the purposes of determining

eligibility in the National Safety Council's Safe Driver Award Program.

Reassignment. References to reassignment in this handbook apply to both voluntary and involuntary reassignments.

Refresher Driver Training. Training given to Postal Service drivers to:

- Help them to maintain defensive driving skills; or
- Address specific local motor vehicle accident causes and contributing factors.

Restricted Information. Information that has limitations placed upon its use within, and its disclosure outside, the Postal Service.

Revocation. The termination of a Postal Service employee's driving privileges.

Satellite LDD. A training, testing, and development center authorized by the Manager, Learning, Development and Diversity, to serve Postal Service employees located away from the main LDD.

Suspension. The temporary withdrawal of an employee's driving privileges in accordance with the provisions of Article 29 of the applicable National Agreement.

Vehicle Familiarization. Training that introduces the unique features of vehicles owned by the Postal Service.

122 Acronyms

The following acronyms are used in this handbook:

| | |
|------|------------------------------------|
| CDL | Commercial driver's license |
| DDC | Defensive Driving Course |
| DSI | Driving Safety Instructor |
| FFV | Flexible Fuel Vehicle |
| GVWR | Gross vehicle weight rating |
| HBK | Handbook |
| LHD | Left-hand-drive |
| LDD | Learning Development and Diversity |
| LMS | Learning Management System |
| MAS | Mirror Adjustment Station |
| OJI | On-the-Job Instructor |
| RHD | Right-hand-drive |
| TTO | Tractor-trailer operator |

13 Program Administration

This subchapter outlines responsibilities by position for administration of the safe driver program.

131 Manager, Safety (Area)

The Manager, Safety (Area), monitors and periodically assesses the administration of all driver selection, safety, and training programs and procedures for the area.

132 Manager, Human Resources (District)

The Manager, Human Resources (District), is responsible for ensuring that all requirements in this handbook are implemented and monitored for compliance.

133 Manager, Learning, Development and Diversity (District)

The Manager, Learning Development and Diversity (District) assists with driver training and ensures that training is recorded in the Learning Management System (LMS).

134 Manager, Safety (District)

The Manager, Safety (District):

- a. Ensures that the driver training program is implemented in accordance with this handbook.
- b. Provides guidance (functional and administrative) to Driving Safety Instructors (DSIs), and Ad Hoc DSIs to ensure that they receive proper training and certification.

135 Driving Safety Instructors

Driving Safety Instructors (DSIs) are Postal Service employees who perform a variety of driver training and testing tasks. The duties and responsibilities of DSIs and Ad Hoc DSIs can be found in chapter 5 of this handbook and in the *Qualification Standard and Standard Position Description for Driving Safety Instructor*, issued by Human Resources.

136 On-the-Job Instructors

On-the-Job Instructors (OJIs) are individuals selected and trained to administer job training to employees at the job site.

136.1 Responsibilities

As part of their training, OJIs are responsible for ensuring that:

- a. New driving employees are provided the allotted time for orientation and training when they arrive at the duty station.
- b. New driving employees use and demonstrate the skills learned in the classroom and the driver skills course.

136.2 Training

OJIs who provide job instruction to new driving employees must complete the following courses successfully:

- a. Job Instructor Training (Course No. 21505-00).

- b. Defensive Driving Course for Postal Delivery Vehicle Operators (Course No. 43601-06).
- c. Defensive Driving Course Debrief (Course No. 43601-06-CL).

14 Program Supervision

This subchapter discusses the role of managers and supervisors, who have a special responsibility for safe motor vehicle operations. Their responsibilities are set forth in:

- a. This handbook (HBK).
- b. HBK EL-801, *Supervisor's Safety Handbook*.
- c. HBK PO-701, *Fleet Management*.
- d. *Employee and Labor Relations Manual* (ELM), Chapter 8.

Managers and supervisors must:

- a. Analyze and review the following to identify driving hazards, contributing factors, and the root causes of motor vehicle accidents: (1) driver observations; (2) route layouts; (3) vehicle accident data; and (4) copies of PS Form 1767, *Report of Hazard, Unsafe Condition, or Practice*, submitted by employees.
- b. Develop, deploy, and review appropriate countermeasures to ensure establishment of an effective safe driver program at their facilities.

141 Observation of Driving Practices

To enforce a high standard of driving performance, supervisors must observe, at a minimum, the number of driving observations shown in [Exhibit 141](#) and complete PS Form 4584, *Observation of Driving Practices*, for each driver under their direct supervision.

Exhibit 141

Observation of Driving Practices

| Postal Service Status | Number of Observations or Frequency of Evaluations |
|---|--|
| Noncareer employees | 1 per FY quarter |
| Probationary employees, with 0–3 months' experience | Evaluations at 30, 60, and 80 days |
| Employees with 4–23 months' experience | 1 per FY quarter |
| Employees with 2 or more years' experience | 2 per FY |

142 Responsibilities

In addition, managers and supervisors must:

- a. Recognize drivers for safe driving and overall safe performance.
- b. Know defensive driving and Postal Service driving techniques and requirements so that they can:
 - (1) Recognize common driving errors.

- (2) Know how to detect driving errors.
- (3) Know how to prevent driving errors.
- c. Check quarterly during the fiscal year to ensure that employees who drive have a current and valid state driver's license or commercial driver's license (CDL) and a Department of Transportation Medical Card.
- d. Schedule employees for driver refresher and improvement training in accordance with this handbook.
- e. Monitor and manage employee driving privileges.
- f. Conduct periodic motor-vehicle-related safety talks.
- g. Perform periodic inspections of all postal-owned and -leased vehicles used in performance of duty, using Notice 76, *Expanded Vehicle Safety Check*.
- h. Perform periodic inspections to identify unreported vehicle damage and initiate and document the investigation of any unreported vehicle damage found.
- i. Report on and investigate all motor vehicle accidents, regardless of injury or amount of damage, and complete required investigative forms.
- j. Send a copy of PS Form 4584 to their servicing DSI, and maintain the form for 4 years.

143 **Learning to Observe Drivers**

Installation heads or supervisors and others who conduct employee driver observations should receive appropriate training, including:

- Driver Observation Training — Delivery Services (Course No. 43601-17), a 2-hour, Web-based course for postmasters with delivery and customer service managers and supervisors.

144 **Evaluating Probationary Employees**

Probationary new drivers and non-driving employees who are reassigned or promoted to positions with driving duties must have their driving practices evaluated after 30, 60, and 80 days (see [Exhibit 141](#)). If a driver's probationary period is other than 90 days, or if the driver does not drive daily (supplemental rural carriers), evaluate the driver at appropriate intervals. The driver's immediate supervisor or other appropriate management official must conduct each observation and evaluation.

144.1 **Evaluation Forms**

Supervisors conduct evaluations to measure and assess a driver's ability to perform the driving duties required for the position safely and successfully. Supervisors must evaluate probationary new drivers on PS Form 1750, *Employee Evaluation and/or Probationary Report*, and PS Form 4584, *Observation of Driving Practices*. (Non-driving employees who are reassigned or promoted to positions with driving duties need be evaluated only on PS Form 4584.)

144.2 **Initial Session with Probationary Employee**

The probationary driver's supervisor must hold an initial session with the employee during the first week at the work site to outline performance expectations. During this initial session, the supervisor must stress the importance of the safe and defensive driving techniques learned during initial driver training.

144.3 **Probationary Employee's Performance**

Before the end of the probationary period, the supervisor must carefully consider and determine whether the employee's driving performance exceeds, meets, or does not meet expectations. The supervisor's determination will be based, at a minimum, on the employee's:

- a. On-duty driving record (accidents and citations).
- b. Ability to improve driving deficiencies identified during the three driving observations.
- c. Ability to demonstrate learned skills for safe and proper driving.

145 **PS Form 4582 – Operator's Record**

145.1 **Newly Hired Drivers**

Effective May 8, 2008, PS Form 4582, *Operator's Record*, is no longer required for newly hired drivers. Effective with this change, all new driver training records must be entered into the LMS.

145.2 **Existing Records**

Each existing PS Form 4582 contains records and information about an individual employee's driver training, which must be maintained as follows:

- a. Managers and supervisors who currently retain PS Forms 4582 for drivers are responsible for updating and maintaining these forms while they are in their possession.
- b. The PS Form 4582 must be maintained until an employee's separation and made available, upon request, to attorneys at the National Tort Center.

15 **Drivers' Responsibilities**

151 **General Principles**

Drivers must recognize that driving for the Postal Service is a privilege and not a right. In addition, they must:

- a. Operate their vehicles in a way that reflects favorably on the Postal Service.
- b. Obey all federal, state, and local traffic laws and Postal Service policies, drive defensively and professionally, and extend courtesy in all situations.

- c. Have in their possession a current and valid state driver's license, or a CDL where required, when operating a vehicle on Postal Service business.
- d. Present the state license or CDL when requested by a manager, supervisor, or DSI.
- e. Observe all driving restrictions placed on them by their state driver's license, their CDL (if applicable), and Postal Service medical personnel.
- f. Inform their supervisor immediately if:
 - (1) They are involved in an accident while performing their duties.
 - (2) Their state driver's license and/or CDL is restricted, suspended, or revoked.
- g. Inspect their vehicles for safety before driving and report deficiencies or safety concerns to their supervisor.

152 **References**

Further information about the duties and responsibilities of drivers is provided in the ELM and the following handbooks:

- a. EL-801, *Supervisor's Safety Handbook*.
- b. EL-814, *Postal Employee's Guide to Safety*.
- c. M-39, *Management of Delivery Services*.
- d. M-41, *City Delivery Carriers Duties and Responsibilities*.
- e. PO-603, *Rural Carrier Duties and Responsibilities*.
- f. PO-701, *Fleet Management*.

This page intentionally left blank

2 Screening and Selecting Drivers

21 Importance of Proper Screening and Selection

The careful screening and selection of applicants who will be granted Postal Service driving privileges is an important element in preventing motor vehicle accidents.

211 **Postal Service Policy**

Postal Service policy is to select for driving positions only those applicants who have demonstrated the ability to use safe driving practices.

212 **Responsibility for Screening**

Postal Service personnel responsible for hiring and providing medical services must ensure that only qualified individuals are hired for driving positions.

213 **Determination of Eligible and Qualified**

The determination of who is eligible and qualified for a position that requires the operation of a motor vehicle as an official duty must be based on the requirements in this handbook and in Handbook EL-312, *Employment and Placement*, Part 516, Driving History.

214 **Determination of Suitable**

The determination of medical suitability for applicants and employees seeking positions that require the operation of a motor vehicle as an official duty must be based on the requirements in Handbook EL-312, subchapter 57, Medical Suitability, and Handbook EL-307, *Reasonable Accommodation in the Workplace: An Interactive Process*.

215 **Human Resources Responsibilities**

Human Resources personnel are responsible for:

- a. Obtaining driving histories for applicants and employees seeking assignment to a position that requires the operation of a motor vehicle as an official duty, as follows:
 - (1) *Applicants*. Obtain driving abstracts that provide 5 years of driving history from every state in which the applicant held a driver's license during the past 5 years.

- (2) *Employees.* Obtain a 5-year driving history on PS Form 2480, a current state driving abstract, and a driving abstract from each state in which the employee held a driver's license during the past 5 years.

Some states may provide only 3 or 4 years of driving history or charge more than a nominal fee to provide a 5-year history. For those states, accept the driving abstract that is routinely provided to determine eligibility.

- b. If an individual's self-reported driving history is more than 90 calendar days old at the time of offer of employment, award of bid, or approval of reassignment or transfer, ask the applicant or employee to update the form.

22 Reviewing Driving Record

221 **Appointing Official's Responsibilities**

The appointing official (or designee) reviews and compares the self-reported driving history to the state driving abstract (or abstracts) to ensure that both documents reflect similar and accurate driving history (see [223](#)). Using the Table of Disqualifications (Handbook EL-312, Exhibit 516.4), the appointing official checks to see if the driving history disqualifies a candidate from further consideration for a position that requires driving as an official duty.

222 **Interpreting Driving History**

The purpose of obtaining (a) the self-reported driving history on PS Form 2480 or in another format, and (b) the state driving abstract (or abstracts) is to help the appointing official determine a candidate's eligibility for a position that requires the operation of a motor vehicle as an official duty.

If the information in the driving abstract is hard to interpret, contact the state agency that issued it for clarification. For out-of-state abstracts, contact a Postal Service employment office in that state for help. DSIs can also help to interpret state driving abstracts.

223 **Resolving Discrepancies**

There may be minor discrepancies between an individual's self-reported driving history and the state driving abstracts. Minor discrepancies between the forms do not indicate an intent to falsify documents — slight differences (e.g., dates) are to be expected. In most cases, the reviewer can resolve minor discrepancies without contacting the individual.

However, if the documents differ significantly, contact the individual to find out the reason for the discrepancy, verify dates, and supply missing information. Do not use the discussion to interpret the severity of convictions. When discrepancies are not satisfactorily resolved, the more stringent of the two documents must be used for purposes of comparison with the Table of Disqualifications.

224 Applicant's Responsibility

If an individual believes that a state driving abstract is inaccurate, he or she is responsible for providing satisfactory evidence of the abstract's inaccuracy. The applicant may provide a new abstract or letter of explanation on appropriate state agency letterhead to the appointing official for an eligibility determination.

225 Employees Who Request Reassignment

When an employee is considered for reassignment to a position that requires driving duties in a different district, and the state driving abstract and the self-reported driving history PS Form 2480 do not meet the criteria specified in the Table of Disqualifications, do not automatically refuse the employee's request.

Instead, review the employee's on-duty driving record, including the PS Form 4582 folder, 5-year safety record, and driver training information provided by the LDD. When reviewing the employee's record to make a determination, the appointing official may consult with the local Manager, Safety (District), but is not obligated to do so.

226 Military Personnel

Every state has provisions for maintaining and renewing licenses while individuals are in the military. Therefore, driving abstracts for recently released military personnel should be available. Occasionally, the state driving abstracts of such individuals will show no history or activity. In such cases, use the information provided by the individual on PS Form 2480, *Driving Record*, to consider eligibility. Additionally, ask the individual to provide a copy of his or her military driving record.

23 Medical Suitability for a Position Requiring Operation of a Motor Vehicle as an Official Duty

Postal Service policy requires applicants for driving positions to meet certain standards of vision and health. The Commercial Motor Vehicle Safety Act of 1986 (Public Law 99-570) places additional requirements on drivers who must have commercial driver's licenses (CDLs).

This subchapter describes the procedures used to assess the vision and health of employees who hold driving positions in the Postal Service.

231 Medical Assessment**231.1 Purpose**

A medical assessment provides the hiring official with the information necessary to make an informed placement decision. The assessment identifies the medical restrictions or limitations that could affect an applicant's ability to perform the job offered in a safe manner.

The medical assessment for an applicant selected for a position requiring operation of a motor vehicle as an official duty is scheduled only after the Postal Service issues a conditional offer of employment to the applicant. Handbook EL-312 sets forth policy for the administration of medical assessments.

Vision is assessed as described in [Exhibit 233](#).

231.2 **Scheduling**

Medical assessments for applicants or current employees will be scheduled sufficiently in advance to allow time to complete all requirements of the medical assessment process. Driving privileges will not be granted or renewed until the medical assessment has been completed and the results have been reviewed by medical personnel and reported to management.

232 **Responsibility for Medical Assessment**

232.1 **Medical Personnel**

Medical personnel will perform medical assessments, as scheduled, for applicants and employees. If the medical assessment process results in the identification of restrictions, limitations, or suggestions for job modification, that does not necessarily indicate the presence of a disability, and it does not constitute a recommendation for or against hiring.

232.2 **Appointing Officials**

Appointing officials use medical assessment findings to determine an applicant's medical suitability for a specific position. See Handbooks EL-307 and EL-312 for policy on medical suitability determinations.

233 **Medical and Vision Requirements for Maintaining Driving Privileges**

Exhibit 233

Medical and Vision Requirements for Maintaining Driving Privileges for Postal-Owned or -Leased Vehicles According to Type of Vehicle

| Type of Vehicle | Requirements |
|--|---|
| Small vehicles such as rural carrier privately owned vehicles, administrative vehicles, pickups, passenger vehicles, and staff cars. | Every 5 years: <ul style="list-style-type: none"> ■ Must possess a valid state driver's license. |
| 10, 000 lbs GVWR or less (excluding the vehicles listed above) Examples: ½-ton, delivery-type vehicles, LLVs, FFVs, GSA vehicles, and minivans. | Every 5 years: <ul style="list-style-type: none"> ■ Must possess a valid state driver's license. ■ Vision exam¹ performed by either Postal Service medical, other designated postal personnel, or contracted medical providers. ■ A vision test conducted by a state motor vehicle office within the last 12 months is acceptable. |

| Type of Vehicle | Requirements |
|--|---|
| <p>10,001 to 26,000 lbs GVWR Examples: 2-ton², 2 ½-ton, and 5-ton cargo vans; wreckers, stake beds, and mobile Post Offices.</p> | <p>Every 5 years:</p> <ul style="list-style-type: none"> ■ Must possess a valid state driver’s license. ■ Medical assessment. ■ Vision exam¹ performed by either Postal Service medical, other designated postal personnel, or contracted medical providers. ■ A vision test conducted by a state motor vehicle office within the last 12 months is acceptable. |
| <p>26,001 lbs GVWR or more Applies to: All vehicles that require the driver to have a CDL (7 tons and up),</p> | <p>Every 2 years:</p> <ul style="list-style-type: none"> ■ Must possess a valid state driver’s license and a certified, current state-issued Department of Transportation CDL. |
| <p>Notes:</p> <ol style="list-style-type: none"> 1. Vision Standard: Monocular correctible to 20/40. 2. Postal Service 2-ton vehicles are considered non-CDL commercial vehicles. | |

This page intentionally left blank

3 Training Drivers

31 Introduction

311 **Philosophy of Driver Training**

Driver training alone will not improve driver performance or reduce motor vehicle accidents. The selection, motivation, periodic observation, and ongoing supervision of Postal Service drivers combine together to make up Postal Service driver training.

312 **Goal and Objectives**

The goal of driver training is to equip Postal Service drivers to:

- a. Drive safely.
- b. Reduce human suffering.
- c. Reduce property damage and costs.
- d. Collect and deliver mail efficiently.
- e. Project a positive image of the Postal Service.

The objectives of the driver training program include the following:

- a. To integrate all elements of the safe driver program.
- b. To develop employees through a systematic, standardized process of training, coaching, mentoring, observing, and correcting.

313 **Types of Driver Training**

To develop and maintain a proficient cadre of drivers, the Postal Service employs three types of driver training:

- a. Initial driver training.
- b. Refresher driver training.
- c. Driver improvement training.

32 Administration

321 **Satellite Sites**

If necessary, satellite driver training locations may be established and approved by the Manager, Human Resources (District).

322 **Lighting**

If adequate artificial lighting is available, vehicle familiarization and controlled driving training can be conducted when it is dark outside. The Manager, Safety, makes the final decision on training after dark.

323 **Documentation**

Responsible officials must document driver training in an approved computer-based application.

324 **Selecting Vehicles**

The DSI must identify the types of vehicles needed for driver training. The manager of the vehicle maintenance facility is responsible for ensuring that the appropriate vehicles (in type and number) are provided when needed.

33 Driver Training

331 **Components**

Driver training consists of the following components:

- a. Web-based driver training.
- b. Vehicle Familiarization.
- c. Skills Course.
- d. Controlled Driving.

Exhibit 331

Right-Hand-Drive Privilege Certification Training

| Required Courses (to be taken in order shown) | Approximate Time in Hours |
|--|----------------------------------|
| Defensive Driving Course for Postal Delivery Vehicle Operators (Course No. 43601-06), Web-based or CD ROM. | 4.00-5.00 |
| DDC Debrief (Course No. 43601-06-CL), debriefing with DSI on Safe Driver Program principles learned in course No. 43601-06, MeetingPlace or Classroom. | 1.00 |
| Vehicle Familiarization (Course No. 19202-03). | 0.75 |
| Skills Course (Course No. 19202-19). <i>DSI sets up this Course and notifies students of date, time, and location.</i> | 3.50 |
| Controlled Driving (Course No. 10020526). | 1.25 |
| Right-Hand Drive Privilege Certification (Course No. 43601-06-CERT) | 1.50 |
| Note: If delivery employee, send to the appropriate carrier academy. | |

Exhibit 331.2

Safe Driver Program Training Matrix

| Training Required/ Driving Privileges Needed | Driving Abstract | State Driver's License | New Hire DDC, No. 100197-63, Web-based | TTO DDC, No. 100197-51 Web-based | CDL and Large Truck Training | DDC for Postal Delivery Vehicle Operators, No. 43601-06, Web-based/CD ROM | DDC Debrief, No. 43601-06-CL | Vehicle Familiarization, No. 19202-03 | Skills Course, No. 19202-19 | Controlled Driving, No. 10020526 | RHD Privilege Certification, No. 43601-06-CERT | City Carrier Academy or Rural Carrier Academy | Large Truck Privileges by Vehicle Type |
|---|-------------------------|-------------------------------|---|---|---|--|-------------------------------------|--|------------------------------------|---|---|--|---|
| New hire – RHD privileges | X | X | X | | | X | X | X | X | X | X | X | |
| New hire – Rural Carrier will use private LHD vehicle | X | X | X | | | | | | | | | X | |
| New hire – Tractor Trailer Operator | X | x | | X | X | | | X | X | X | | | X |
| Reassigned employee – RHD Privileges | X | X | | | | X | X | X | X | X | X | X | |
| Rural Carrier moving from LHD Vehicle – RHD privileges | | X | | | | X | X | X | X | X | X | | |
| Rural Carrier – RHD privileges for privately owned RHD | | | | | | X | X | | X | | | | |
| FFV replacing LLV – Driver has RHD privileges | | | | | | | | X | | | | | |
| Employee – RHD privileges as an incidental driver | X | X | | | | X | X | X | X | X | X | | |
| Employee Needs Driving Privileges for: | | | | | | | | | | | | | |
| 1-ton vehicle | | | | | | | | X | X | X | | | X |
| 1½-ton vehicle | | | | | | | | X | X | X | | | X |
| 2-ton vehicle* | | | | | | | | X | X | X | | | X |
| 5-ton vehicle | | | | | | | | X | X | X | | | X |
| 7-ton vehicle | | | | | X | | | X | X | X | | | X |
| 11-ton vehicle | | | | | X | | | X | X | X | | | X |
| Tow Truck** | | | | | X | | | X | X | X | | | X |

* If this employee is a new hire, he or she must also take New Hire DDC, Course No. 100197-63 (Web-based).

** Some tow trucks require a CDL.

332 **Incidental Drivers and Non-driving Employees**

332.1 **Incidental Drivers**

332.11 **Definition**

Incidental drivers are Postal Service employees (bargaining or nonbargaining), including postmasters, postmaster reliefs, managers, supervisors, and other administrative, technical, and clerical employees who:

- a. Hold positions that do not normally require regular driving; or
- b. Hold positions in which driving is incidental to their duties; and
- c. Operate only their own personal vehicles or administrative passenger vehicles.

332.12 **Training**

Based on local accident data, districts may choose to provide specialized refresher training for incidental drivers.

332.13 **Categories**

Incidental drivers are divided into two broad categories: (a) those who drive left-hand-drive (LHD) passenger vehicles; and (b) those who drive right-hand-drive (RHD) vehicles. These categories apply whether the employees are tenured or newly hired.

332.131 **Left-Hand-Drive Vehicles (Postal or Privately Owned)**

Incidental drivers of postal or privately owned LHD passenger vehicles must have a current and valid state driver's license.

332.132 **Right-Hand-Drive Vehicles**

Incidental drivers of postal-owned RHD vehicles are required to complete all phases of driver training, as follows:

- a. Defensive Driving Course for Postal Delivery Vehicle Operators (Course No. 43601-06).
- b. DDC Debrief (Course No. 43601-06-CL).
- c. Vehicle Familiarization (Course No. 19202-03).
- d. Skills Course (Course No. 19202-19) and practice driving.
- e. RHD Privilege Certification (Course No. 43601-06-CERT).

332.2 **Non-driving Employees**

A non-driving employee who is directed to attend and elects to drive to official seminars or meetings using his or her own LHD vehicle is not required to complete initial driver training. The employee must have a current and valid state driver's license.

332.3 **Drivers Hired by Rural Carriers**

Article 29.5 of the National Rural Letter Carriers' Agreement allows rural carriers to hire a non-postal driver to drive them around on their route in the employee's (carrier's) personal vehicle. If they use an LHD vehicle, these non-postal drivers are not required to attend driver training or pass any of the driver training exams. The rural carrier's supervisor must validate the non-

postal driver’s current and valid state driver’s license and appropriate required insurance.

If the employee wishes to use an RHD personal vehicle, the rural carrier must contact his or her supervisor regarding additional requirements.

333 Training Requirements for Driving Employees With Breaks in Service

333.1 Verification of License and Review of Records

An individual with a break in service must have a current and valid state driver’s license. Before reinstating or reappointing an employee with a break in service to a driving position, the appointing official must review the individual’s on-duty driving and accident records.

333.2 Summary of Training Requirements

Exhibit 333.2

Summary of Training Requirement

| Break in Service or Break in Driving Privilege Status | Vehicle Familiarization Required? | Skills Course and Controlled Driving Required? | Comments |
|--|--|---|---|
| Break exceeds 1 year – regardless of driving privileges held when break occurred | Yes | Yes | RHD Privilege Certification Training is required for those who need to drive postal-owned RHD vehicles. |
| Break of less than 1 year – has had driving privileges on required vehicles | No | No | No training required. |

334 Web-based Driver Training

334.1 Description

Exhibit 334.1

Web-based Driver Training

| Title of Course | Number | Description | No. of Hours | Format |
|--|-------------|--|--------------|---------------------------|
| Defensive Driving Course for Postal Delivery Vehicle Operators | 43601-06 | Defensive driving for operators of delivery vehicles, RHD vehicles, LLVs, and FFVs | 4–5 | Web-based or CD ROM |
| DDC Debrief* | 43601-06-CL | Debriefing facilitated by a DSI | 1 | MeetingPlace or Classroom |
| New Hire DDC | 100197-63 | Generic defensive driving for all drivers | 1 | Web-based |
| Defensive Driving: Tractor-Trailer Operator (TTO) Truck Safety | 100197-51 | Training for TTOs | 3 | Web-based |

* The Facilitator and Student Guides for the DDC Debrief are located on the Safety Resource Web page, under USPS Safety Programs/DSI. The URL is: <http://safetytoolkit.usps.gov:12/dsi.aspx>.

335 Vehicle Familiarization

335.1 Description

Vehicle familiarization, the second component of driver training, is usually conducted in conjunction with the skills courses described in [336](#), Controlled Driving – Skills Course and Street Drive, and Appendices A, B, C, and D. Vehicle familiarization training may take up to 45 minutes for each vehicle.

335.2 Purpose

The purpose of vehicle familiarization is to explain and demonstrate the components and operating characteristics of a vehicle owned by the Postal Service.

335.3 Content

The main focus of vehicle familiarization is teaching the driver how to use Notice 76, *Expanded Vehicle Safety Check*. The training also includes:

- a. Participating in mirror adjustment activities for long-life vehicles (LLVs) and flexible-fuel vehicles (FFVs) using the LLV/FFV Mirror Station in Appendix A.
- b. Demonstrating and explaining how to:
 - (1) Use seatbelts.
 - (2) Overcome blind spots.
 - (3) Identify cockpit controls.
 - (4) Locate and use the accident kit.
 - (5) Use rear vision cameras, monitors, and microphones (where appropriate.)
 - (6) Use keyless entry and ignition systems (where applicable).
 - (7) Start and park vehicles properly.

- (8) Use rear vehicle power lifts (where applicable).
- (9) Understand vehicle clearances (horizontal and vertical).
- (10) Understand a vehicle’s unique features (such as RHD, turning radius, and mirrors).
- (11) Use vehicle doors and windows (closing and locking procedures).
- c. Using Job Safety Analysis to:
 - (1) Identify hazards associated with entering and exiting a vehicle.
 - (2) Understand proper fueling procedures for gasoline and alternative fuels.
- d. Identifying hazards associated with the rear bumpers of LLVs and FFVs.
- e. Securing vehicles properly against theft in accordance with Postal Service national policy.
- f. Reporting a motor vehicle accident according to national and local procedures and requirements.

335.4 **Drivers Required to Take Vehicle Familiarization**

Exhibit 335.4

Drivers Required to Take Vehicle Familiarization

| If a Postal Service employee... | Then the employee... |
|--|---|
| <ul style="list-style-type: none"> ■ Is a new hire city/rural carrier; or ■ Does <i>not</i> have driving privileges for a specific kind of vehicle; or ■ Is a new operator required to have a CDL | Must complete vehicle familiarization training on each type of Postal Service vehicle he or she is required to operate. |
| <ul style="list-style-type: none"> ■ Is a new or currently employed rural carrier required to operate a postal-owned RHD vehicle | Must complete training for RHD privileges on a postal-owned RHD vehicle. |
| <ul style="list-style-type: none"> ■ Has driving privileges for job duty (meets the requirements to drive a specific kind of vehicle); or ■ Is a new rural carrier <i>not</i> required to operate a postal-owned RHD vehicle | Is <i>not</i> required to complete vehicle familiarization training. |

335.5 **Selecting Vehicles**

Familiarization training must be provided for each type of Postal Service vehicle that trainees are required to operate on the job. The DSI must identify the types of vehicles needed for familiarization. The vehicle maintenance manager is responsible for ensuring that the appropriate vehicles (in type and number) are provided when needed.

336 **Controlled Driving – Skills Courses and Street Drive**

336.1 **Purpose**

Controlled driving is a training activity. The components of controlled driving – the skills course and the street drive – are designed to provide learning

opportunities for student drivers. Controlled driving is conducted on the driver training skills courses (described in Appendices [B](#), [C](#), and [D](#)) and on the street by a DSI.

The purpose of controlled driving, especially the street drive, is to give employees who drive the opportunity to:

- a. Practice and apply skills learned.
- b. Practice driving specific Postal Service vehicles as they will be used on the job.

336.2 **Description**

Controlled driving training consists of two separate and distinct components:

- a. Skills course (no more than 3½ hours for each type of vehicle).
- b. Street drive (45 minutes for each type of vehicle).

336.3 **Skills Course**

Each student takes the appropriate postal-designed skills course, as follows:

- a. Driving RHD delivery vehicles (see Appendix [C](#)).
- b. Driving large trucks, including 2-ton trucks, 5-ton trucks, and all vehicles that require a CDL (see Appendix [D](#)).

Before conducting skills course training, the DSI must:

- a. Review each individual's state driver's license, especially for driving restrictions.
- b. Ask students about Postal Service medical restrictions and state driving restrictions (such as corrective lenses, glasses left, or glasses right).

Every driver must adhere to state and Postal Service medical requirements when taking controlled driving training and when operating a vehicle on duty.

336.4 **Street Drive**

336.41 **Purpose**

The purpose of street-drive training is to have the student apply and practice what was learned in online training, in vehicle familiarization, and on the skills course to real-life driving on the street. The 45-minute, vehicle-specific street drive is administered after skills course instruction and before RHD Privilege Certification. For CDL operators this includes a 15-minute pre-drive safety check.

336.42 **Content**

Street-drive training includes practicing maneuvers in situations:

- a. Similar to those experienced on the skills course.
- b. Encountered on the street, such as changing lanes, in-lane driving, and maintaining following distances.

For postal-owned RHD delivery vehicles, all street practice driving will be done in the LLV. No street practice driving is to be conducted in the FFV.

336.43 Role of the DSI

DSIs are expected to provide instruction, feedback, and guidance during the street drive.

DSIs may terminate the street practice drive when appropriate.

336.5 Delivery Skills Course**336.51 Purpose**

The purpose of the delivery skills course is to train drivers how to use postal-owned vehicles to deliver the mail safely and effectively. The DSI is responsible for ensuring that the delivery skills course is set up correctly and conducted safely.

336.52 Content

The delivery skills course includes training in the following skills:

- a. Using vehicle controls (where applicable, including rear vision cameras and monitors).
- b. Exiting and entering a vehicle safely.
- c. Adjusting mirrors.
- d. Parking safely (including parallel parking).
- e. Backing up safely (including offset backing).
- f. Navigating intersections.
- g. Making angled turns.
- h. Delivering mail curbside.
- i. Navigating overhead clearances.
- j. Making 3-point turns and U-turns.
- k. Parking and securing a vehicle.
- l. Turning.
- m. Stopping.
- n. Learning other practices as dictated by local accident data.

336.6 Large-Truck Skills Course**336.61 Purpose**

The purpose of the large-truck skills course is to assess skills and train drivers on the use of large Postal Service trucks (including 2-ton trucks, 5-ton trucks, and vehicles that require a CDL).

336.62 Content

The large-truck skills course includes:

- a. Parallel parking.
- b. Offset maneuvering and backing up.
- c. Forward stopping, straight line maneuvering, and backing up.
- d. Rear swing clearances — understanding, managing, and avoiding curb overhangs.
- e. Maneuvering around and backing up to alley docks.

336.7 **Drivers Required to Take Controlled Driving Training**

Exhibit 336.7

Drivers Required to Take Controlled Driving Training

| If a Postal Service employee... | Then the employee... |
|--|--|
| <ul style="list-style-type: none"> ■ Is a new hire city or rural carrier required to operate a postal-owned RHD vehicle or a non-CDL postal-owned cargo vehicle; or ■ Is a current employee who does <i>not</i> have driving privileges for a specific type of RHD vehicle or non-CDL cargo vehicle, and is required to operate that vehicle; or ■ Is a new operator required to have a CDL | Must successfully complete controlled driving training on each type of Postal Service vehicle he or she is required to operate. |
| <ul style="list-style-type: none"> ■ Is a new or current rural carrier required to operate a postal-owned RHD vehicle | Must successfully complete controlled driving training on a postal-owned RHD vehicle. |
| <ul style="list-style-type: none"> ■ Is a new rural carrier <i>not</i> required to operate a postal-owned RHD vehicle | Is <i>not</i> required to complete controlled driving training on a postal-owned RHD vehicle (unless a supervisor specifically requests it). |

336.8 **Hours of Instruction**336.81 **Delivery Skills Course**

Training time required for controlled driving on the delivery skills course:

- a. *Minimum*: 3 hours for each vehicle
- b. *Maximum*: 3½ hours for each vehicle.

336.82 **Large-Truck Skills Course**

The maximum time required for controlled driving on the large-truck skills course is 3 hours for each type of vehicle.

337 **End-of-Training Certification**337.1 **Purpose**

The purpose of the end-of-training certification is to measure the individual's ability to apply the skills learned. Employees must obtain Postal Service driving privileges for postal-owned vehicles.

337.2 **Description — RHD Privilege Certification**

The DSI administers RHD Privilege Certification using an LLV after an individual completes the allotted time for the street practice drive. Individuals who complete controlled driving training for both LLVs and FFVs will take one end-of-training RHD Privilege Certification using an LLV. FFVs will not be used for RHD Privilege Certification. The RHD Privilege Certification Form and completion instructions are located on the Safety Resources Web page under USPS Safety Programs/DSI. The URL is: <http://safetytoolkit.usps.gov:12/dsi.aspx>.

The certification must be conducted on the street.

337.3 **Drivers Required to Obtain the RHD Privilege Certification**

Exhibit 337.3

Drivers Required to Obtain the RHD Privilege Certification

| If a Postal Service employee... | Then the employee... |
|--|---|
| <ul style="list-style-type: none"> ■ Is a new hire city or rural carrier who has completed controlled driving training on a postal-owned RHD; or ■ Is a current employee who does <i>not</i> have driving privileges for a specific type of postal-owned RHD vehicle for job duty, and requests a promotion or reassignment to a city or rural carrier position that requires driving a specific type of postal-owned RHD vehicle for job duty | <p>Must be certified for the postal-owned RHD vehicle he/she is required to operate.</p> <p>Note: Employees who have received training on postal-owned LLVs and FFVs and are required to obtain RHD Privilege Certification will use an LLV.</p> |
| <ul style="list-style-type: none"> ■ Is a current employee reassigned to a city or rural carrier position in another district, and has current driving privileges for a postal-owned RHD vehicle | <p>Is <i>not</i> required to take additional RHD training.</p> |

337.4 **Description — Other Postal Service Vehicle Privilege Certification**

The DSI certifies all vehicle privileges after an individual successfully completes the required training on a specific type of postal-owned vehicle per [Exhibit 331.2](#).

337.5 **Failure to Receive Certification**

Individuals who do not receive certification on a specific type of postal-owned RHD vehicle will not be granted Postal Service privileges for that type of vehicle. This applies whether the employee is a newly hired city or rural carrier or is requesting promotion or reassignment.

Human Resources will provide official notification to the employee and the employee’s supervisor.

34 Refresher Driver Training

341 **When to Conduct**

Refresher driver training should be conducted when:

- a. Trends in local motor vehicle accident data suggest additional driver training is needed.
- b. Driver training programs or awareness campaigns are conducted and deficiencies are demonstrated.

342 **Content**

Refresher driver training can include any of the following:

- a. Skills course on the lot (Course No. 19202-19).

- b. Vehicle Familiarization (Course No. 19202-03).
- c. Controlled Driving on the street or on the carrier's line of travel (Course No. 10020526).
- d. DDC (Course No. 43601-06), Web-based or CD ROM.

35 Driver Improvement Training

351 **When to Conduct**

A driver who has completed initial driver training must take driver improvement training when the:

- a. Driver is deemed at fault in a motor vehicle accident.
- b. Supervisor recommends training based on observations of driving practices.

Driver improvement training will take place within 10 calendar days of an accident or observation of an unsafe driving practice.

352 **Content**

Driver improvement training must address the driver's specific driving deficiencies and use positive reinforcement. Any of the following activities may be employed in driver improvement training:

- a. Direct the driver to take Postal Service Defensive Driving (Course No. 43601-06, Web-based or CD ROM).
- b. Discuss driving observations with the driver.
- c. Discuss and review the accident scene and circumstances with the driver.
- d. Conduct vehicle familiarization.
- e. Conduct training at one or more stations on the skills course.
- f. Conduct a controlled driving exercise on the street or route where the driver experienced difficulties.

353 **Documentation**

Document all employee refresher and driver improvement training.

36 Special Emphasis Vehicle Orientation

The Postal Service does not consider special emphasis vehicle orientation to be formal training.

361 **When to Conduct**

Special emphasis vehicle orientation is appropriate when any of the following are changed or modified:

- a. State motor vehicle laws.

- b. Postal Service policies, rules, and regulations for driving.
- c. Motor vehicle fleet.

Special emphasis vehicle orientation is also appropriate when a purchased or deployed vehicle is:

- a. Similar to a model in fleet inventory (new model of a tractor or 7-ton vehicle).
- b. A commercial, off-the-shelf, LHD vehicle (minivan or sport utility vehicle).

362 **Content**

Depending on the situation, special emphasis vehicle orientation may include one or more of the following activities:

- a. Giving a safety talk.
- b. Presenting a manufacturer's video, discussing it, and following up with a question and answer session.
- c. Discussing and demonstrating the unique features of a specific vehicle model.
- d. Providing drives (skills course or on-the-street).
- e. Conducting vehicle familiarization as outlined in 335.

363 **Documentation**

Special emphasis vehicle orientation does not require documentation.

This page intentionally left blank

4 State Driver's Licenses

41 Requirements

411 **Employees' Responsibilities**

In order to maintain Postal Service driving privileges, an employee must:

- a. Have a current and valid state driver's license in his or her possession.
- b. Observe and apply any restrictions imposed by state and Postal Service medical personnel.
- c. Produce the license when asked to do so by a Postal Service manager, supervisor, or DSI.

In addition, drivers must inform their supervisors immediately if their state driver's or commercial driver's licenses (CDLs) are suspended or revoked. Failure to do so may result in administrative action.

412 **Supervisors' Responsibilities**

To verify the existence of current and valid licenses, supervisors must require each driver to produce his or her state driver's license or CDL once every quarter. If a Postal Service driver fails to provide evidence of a current and valid state driver's license or CDL, the supervisor must:

- a. Suspend or revoke the driver's Postal Service driving privileges until the existence and validity of the license is verified.
- b. Refer to Article 29 of the appropriate collective bargaining agreement to determine whether rights or obligations exist concerning reassignment to non-driving duties.

413 **Incidental Drivers and Non-driving Employees**

The following Postal Service employees are required to have current and valid state driver's licenses:

- a. Incidental drivers who operate vehicles (private or leased or owned by the Postal Service) on official Postal Service business.
- b. Non-driving employees who are directed to attend and elect to drive to official seminars or meetings using their own vehicles.

414 **Special Requirements for Operators With CDLs**

All Postal Service drivers who are required to have a CDL as part of their job duties must abide by all current requirements of the Commercial Motor

Vehicle Safety Act of 1986 (Public Law 99-570). In accordance with the Act and in part:

- a. Within 30 days of a conviction for any traffic violation, except parking, a driver with a CDL must notify his or her employer, regardless of the nature of the violation or the type of vehicle that was driven at the time.
- b. If a CDL is suspended, revoked, or cancelled or if the employee is disqualified from driving, the employee must notify his or her supervisor. This notification must be made by the end of the next business day following receipt of the notice of the suspension, revocation, cancellation, lost privilege, or disqualification.
- c. PS Form 4600, *Driver Notification and Compliance Certificate*, completed during the application process, must be retained by the local Human Resources office, with a copy given to the driver.
- d. Supervisors may not knowingly use a driver who: (1) has more than one CDL; (2) whose CDL is suspended, revoked or cancelled; or (3) is disqualified from driving. Violation of this requirement may result in civil or criminal penalties.
- e. The federal penalty to a driver who violates the CDL requirements is either: (1) a civil penalty of up to \$2,500; or (2) in aggravated cases, criminal penalties of up to \$5,000 in fines, up to 90 days in prison, or both.

42 Suspension and Revocation of Driving Privileges

421 Reason for Suspension or Revocation

421.1 For Physical Condition

421.11 Responsibilities

Each employee must continue to meet the physical standards required to obtain a state driver's license or state CDL in the state that has granted the license. Employees have a responsibility to inform their supervisors of any change in physical condition that may adversely affect their driving abilities. Postal Service personnel may learn that an employee's physical condition is such that the employee's state driving privilege should be suspended. When this happens, the appropriate supervisor will consider suspending the employee's Postal Service driving privileges until the condition is corrected or under adequate control. See [Exhibit 421.12](#).

421.12 **Procedures**

Exhibit 421.12

Procedures to Suspend or Revoke Postal Service Driving Privileges

| If a Postal Service... | Then the supervisor must... |
|--|--|
| Driving employee's state driving privilege is suspended or revoked | <ul style="list-style-type: none"> ■ Suspend or revoke the employee's Postal Service driving privileges. |
| Driving employee's physical condition is permanent | <ul style="list-style-type: none"> ■ Temporarily suspend Postal Service driving privileges and remove employee from any position that requires driving. ■ Consult with the employee and medical personnel to determine if the employee is able to drive. ■ Engage the District Reasonable Accommodation Committee (DRAC) interactive process. |
| Driving employee's physical condition may have changed | <ul style="list-style-type: none"> ■ Temporarily suspend Postal Service driving privileges. ■ Consult with the employee and with Postal Service medical personnel. ■ Engage the DRAC interactive process. |
| Driving employee requests reasonable accommodation | <ul style="list-style-type: none"> ■ Consult with the DRAC. |

421.2 **For Unsafe Driving**

421.21 **On-duty Record**

When the on-duty record shows that an employee is an unsafe driver, management may suspend or revoke the employee's Postal Service driving privileges. Elements of the on-duty record that may be used to suspend or revoke driving privileges include:

- a. Traffic law violations.
- b. Accidents.
- c. Failure to meet motor vehicle operational standards.
- d. Disregard for personal safety.

421.22 **Procedures**

The following guidelines apply:

- a. When management is considering the suspension, revocation, or re-issuance of an employee's driving privileges, the final determination must be based solely on the employee's on-duty driving record.
- b. Management must automatically:
 - (1) Suspend or revoke an employee's driving privileges when a state driver's license is suspended or revoked.
 - (2) Restore an employee's driving privileges when the state driver's license is restored.

- c. If the suspension or revocation states that the employee may operate a vehicle for employment purposes, then Postal Service driving privileges must not be suspended or revoked automatically.
- d. When management is considering the suspension, revocation, or re-issuance of an employee's driving privileges based on the on-duty driving record, the conditional suspension or revocation of a state driver's license may be considered in making the final determination.
- e. When a state driver's license is reinstated, the employee must provide documentation to that effect.

421.3 **In Case of Accident**

When an employee is involved in a motor vehicle accident:

- a. There are no provisions for the automatic suspension of an employee's driving privilege based on the fact that the employee was involved in a motor vehicle accident.
- b. The individual circumstances surrounding each accident are assessed at the time of the accident to determine whether a temporary suspension of driving privileges is warranted.
- c. The supervisor must consider whether public safety or the employee's safety will be jeopardized if the employee is allowed to continue driving.
- d. The supervisor (and/or other Postal Service managers) must assess factors related to the accident, to include the following:
 - (1) Employee's condition. For example:
 - (a) Shock.
 - (b) Fatigue.
 - (c) Impairment caused by use of alcohol or controlled substances.
 - (d) Other physical or emotional factors.
 - (2) Seriousness of the unsafe driving practice (if any) that contributed to the accident.

422 **Temporary Suspension of Driving Privileges**

If the supervisor cannot make an immediate determination based upon a review of the factors listed in [421.3](#), the supervisor may temporarily suspend the employee's driving privileges pending completion of an investigation. Once the investigation is completed, the supervisor can make the decision to suspend, revoke, or reinstate driving privileges.

Driving privileges may be withheld pending investigation for no more than 14 calendar days, after which the employee's driving privileges must be:

- a. Reinstated;
- b. Suspended up to 60 days; or
- c. Revoked.

If the employee's driving privileges are suspended or revoked, the supervisor must explain to the employee, in writing, the reasons for the action.

423 **Decision Criteria**

Management makes a decision to suspend or revoke driving privileges according to the following criteria:

- a. Investigate and determine the driver's:
 - (1) Fault or lack of fault (were the driver's actions the primary cause of the accident?).
 - (2) Degree of error.
 - (3) Record (on-duty driving history, prior corrective actions related to motor vehicle operation).
- b. Consider the severity of the accident.
- c. Consider factors about the driver such as:
 - (1) Training (quality or absence of training in a particular driving activity).
 - (2) Physical condition (did the employee meet the physical standards required by state licensing laws at the time of the accident?).

Note: A Safe Driver Award Committee determination about the preventability of an accident is *not* a factor to be considered when suspending or revoking driving privileges.

424 **Special Cases**

424.1 **Consideration of Suspension or Revocation of Driving Privileges**

In certain cases, supervisors (or other officials) must consider suspending or revoking an employee's driving privileges .

Supervisors (or other officials) must take action when a Postal Service driver's on-duty driving record indicates one or more of the following:

- a. Two or more at-fault accidents within a 12-month period.
- b. Two or more convictions by civil authorities for moving traffic violations within a 12-month period.
- c. Repeated violation of Postal Service driving regulations or safe driving practices, rules, and regulations after being warned or instructed.
- d. Disregard for his/her own personal safety.
- e. Disregard for the safety of others.
- f. Supervisor's determination that retaining the employee on duty could result in:
 - (1) Damage to Postal Service property.
 - (2) Loss of mail or funds.

424.2 **Request for Reinstatement of Driving Privileges**

If an employee requests reinstatement of revoked or suspended driving privileges, management must review the request and make a decision as soon as possible, but not later than 45 days from the date of the employee's request. If the request is denied, management must convey the decision to the employee *in writing*.

424.3 **Reassignment**

When the driving privileges of a career bargaining unit employee are suspended or revoked, refer to Article 29 of the applicable collective bargaining agreement to determine whether rights or obligations exist concerning reassignment to non-driving duties.

5 Driving Safety Instructors

51 Duties and Responsibilities

Driving Safety Instructors (DSIs):

- a. Conduct initial driver training, some types of refresher driver improvement training, and special emphasis vehicle orientation.

Note: The DSI may recommend appropriate Web-based refresher and driver improvement training for drivers to complete at their duty stations.

- b. Coach drivers and observe driving practices.
- c. Train and evaluate Ad Hoc DSIs.

For more detailed information about DSI duties and responsibilities, see *Qualification Standard and Standard Position Description for Driving Safety Instructor (Qualification Standard)*, issued by Human Resources.

52 Selection, Training, and Certification

521 Selection

The careful selection, training, and certification of qualified personnel to act as DSIs are of critical importance to the Postal Service's safe driver program. Selection of DSIs is the joint responsibility of the installation head and the safety manager. Select the most qualified candidates office-wide for DSI positions, regardless of craft.

A prospective DSI must meet the selection criteria and job requirements of the *DSI Qualification Standard* before being designated as a DSI and receiving any job-related DSI training.

522 Training

Prospective DSIs must meet the training requirements of the *Qualification Standard* by completing the Ad Hoc Driver Safety Instructor Program (Course No. 19201-90).

523 Certification

The Manager, Safety (District) documents all training requirements on PS Form 2432, *Individual Training Progress Report*, and submits all certification forms with PS Form 2432.

524 **Uniforms, Activity Codes, and Training**

524.1 **Uniform Allowances**

Full-time DSIs are eligible for a uniform allowance. Ad Hoc DSIs are not eligible for a uniform allowance unless they are already entitled to a uniform allowance based on their regular assignment. See ELM 932.1, Employees Required to Wear Uniforms and Work Clothes, for additional information.

524.2 **Activity Codes**

The codes for full-time DSIs are as follows:

- a. *Occupation Code: 5703-0006.*
- b. *Designation Activity Code: 135.*
- c. *Labor Distribution Code: 63.*

524.3 **Facilitative Instructor Workshop**

For information on the Facilitative Instructor Workshop (Course No. 21201-61), consult the Manager, Learning, Development and Diversity (District).

53 **Ad Hoc Driving Safety Instructors**

531 **Duties and Responsibilities**

Ad Hoc DSIs are Postal Service employees who:

- a. Perform DSI duties part time, seasonally, and as needed.
- b. Are qualified to instruct other employees to drive vehicles used in Postal Service operations.

532 **Selection, Training, and Certification**

Ad Hoc DSIs must meet the same selection, training, and certification requirements as full-time DSIs. Ideally, Ad Hoc DSIs will teach at least three or four times a year to maintain proficiency.

Managers and supervisors of Ad Hoc DSIs must support the safety function by releasing these individuals when needed by a Manager, Safety, or Learning, Development and Diversity.

Appendix A

Mirror Adjustment Stations

Appendix A describes how to set up a mirror station to adjust the seven mirrors found on the long-life vehicle (LLV) and the flexible-fuel vehicle (FFV). It also describes activities designed to emphasize the importance of properly adjusted mirrors.

Exhibit A-1
Mirror Adjustment Station

This is a diagram of the painted lines and squares for a mirror adjustment station (MAS) used to accommodate both LLVs and FFVs.

The MAS is 7 feet wide and 15 to 17 feet long. An LLV is 15 feet long; an FFV is 17 feet long.

At this station all seven mirrors will be properly adjusted so the driver can see:

- Three corners of the station.
- Front and rear bumpers.
- Right and left sides of the vehicle.

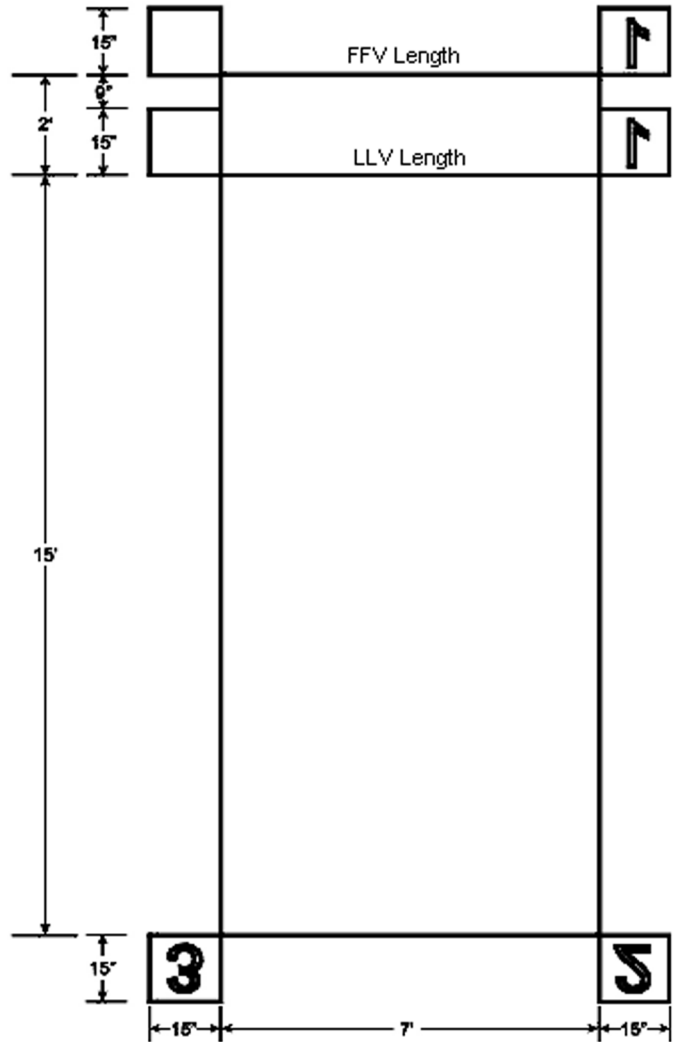

Note: If the numbers 2 and 3 are painted backwards and upside down, the driver sees them correctly when looking into the rearview mirror.

Exhibit A-2.1

Mirror Adjustment Station 1

With the help of another person, the driver parks the LLV or FFV in the center of the MAS box. The front line of the station must run directly in front of the bumper.

Adjust the right side convex mirror (mirror 1) so the driver can see the number 2 painted at the right rear corner of the station and also see the right rounded corner of the rear bumper.

Note: If the number 2 is painted backwards and upside down, the driver sees it correctly when looking into the rearview mirror

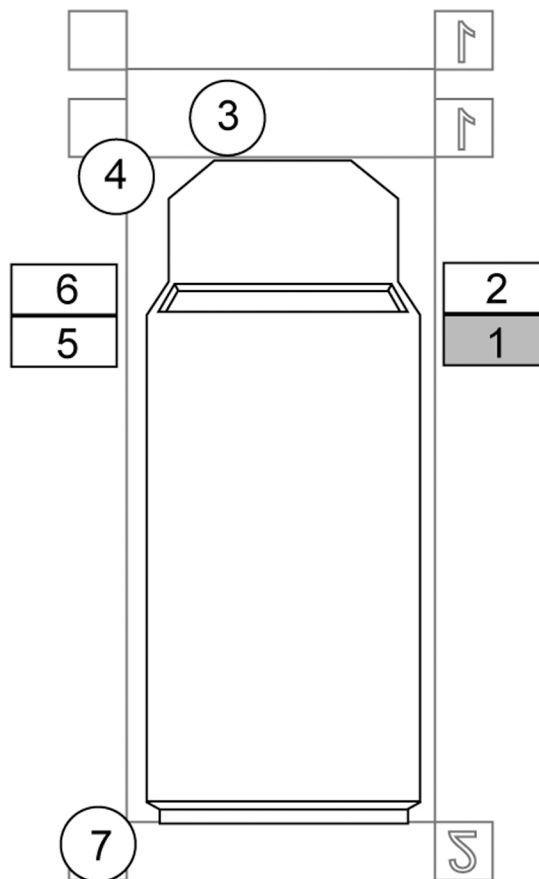

Exhibit A-2.2
Mirror Adjustment Station 2

Adjust the large flat mirror on the right-hand side (mirror 2) so the driver can see objects 300 to 500 feet to the rear and a small portion of the right-hand side of the vehicle.

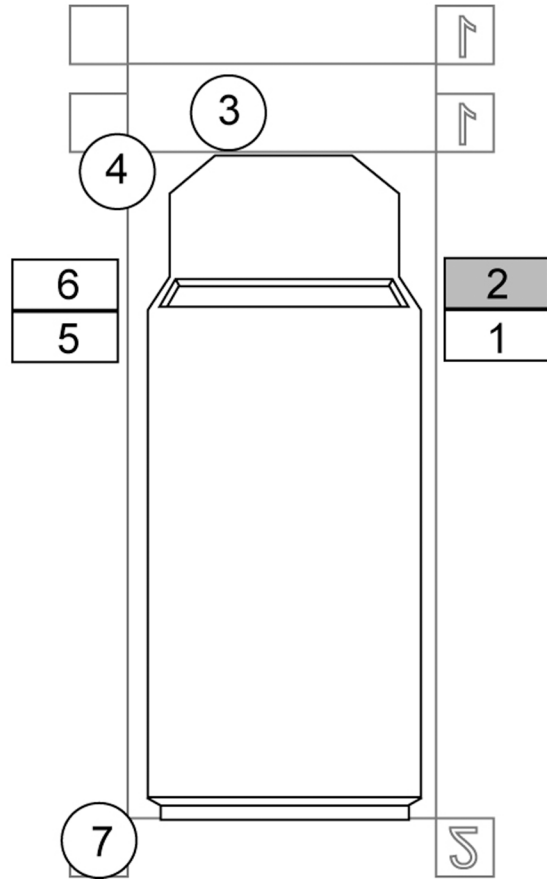

Exhibit A-2.3

Mirror Adjustment Station 3

Adjust the front pot-lid mirror (mirror 3) so the driver can see the front bumper and the number 1 at the right front corner.

If the number 1 is painted backwards, the driver sees it correctly when looking in the mirror.

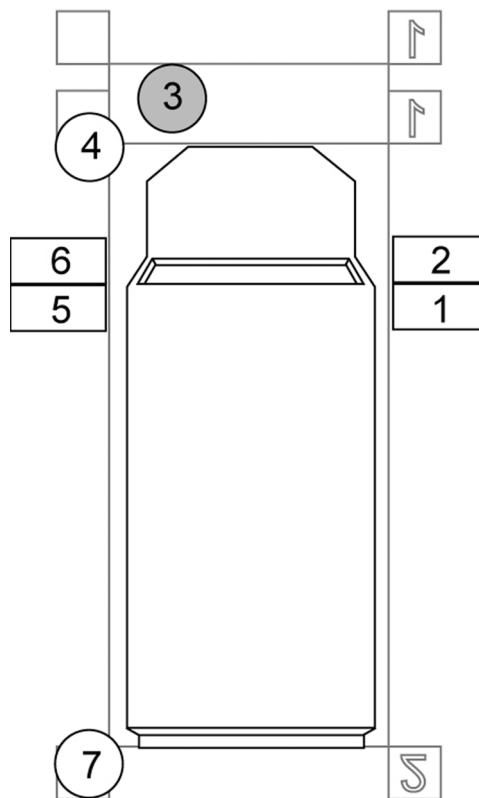

Exhibit A-2.4
Mirror Adjustment Station

Adjust the pot-lid mirror on the left-hand side (mirror 4) so the driver can see the entire left side of the LLV or FFV from the front-marker light to the rear bumper and beyond.

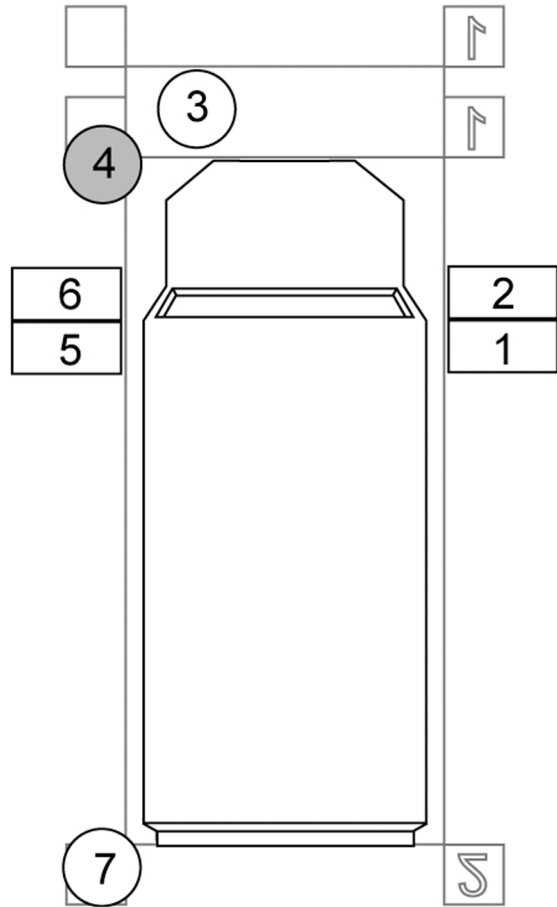

Exhibit A-2.5

Mirror Adjustment Station 5

Adjust convex mirror 5 on the left-hand side so the driver can see a small portion of the left side of the vehicle and the painted number 3 (obscured by mirror 7 in this diagram) at the left rear corner.

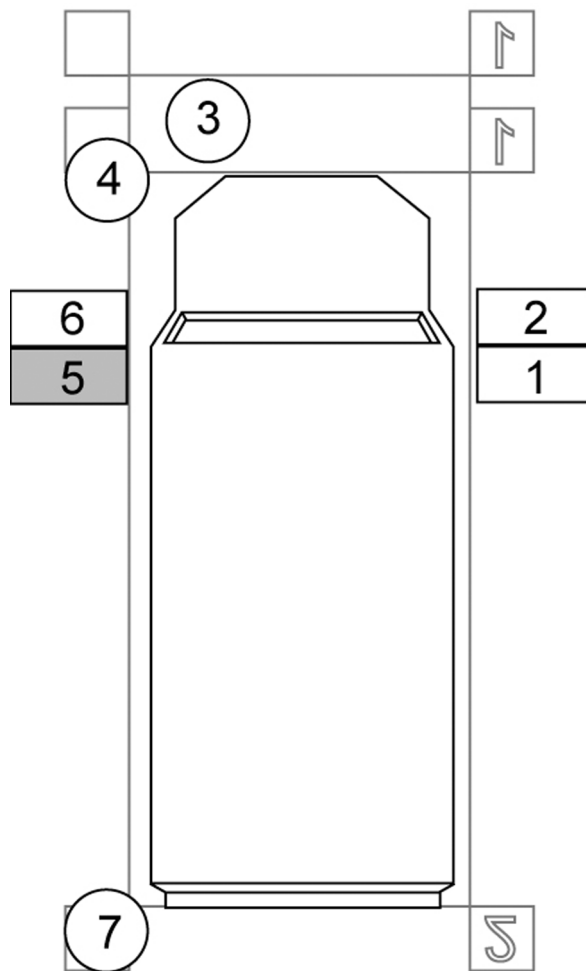

Exhibit A-2.6
Mirror Adjustment Station

Adjust large, flat mirror 6 on the left-hand side so the driver can see objects 300 to 500 feet to the rear and a small portion of the left side of the LLV or FFV. The driver must also be able to see the high pot-lid mirror (number 7) on the rear of the vehicle.

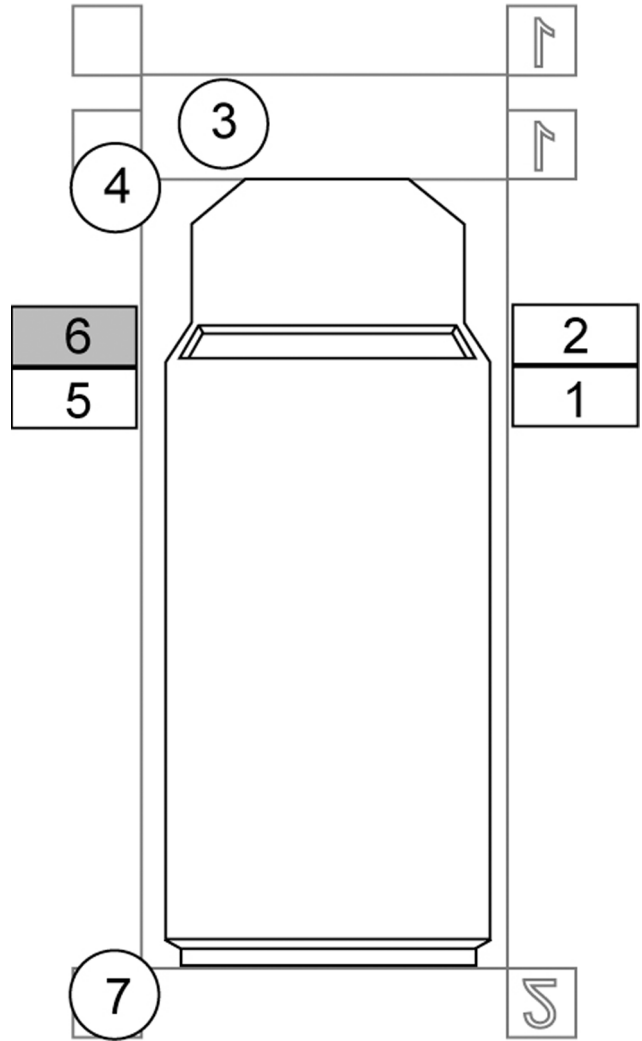
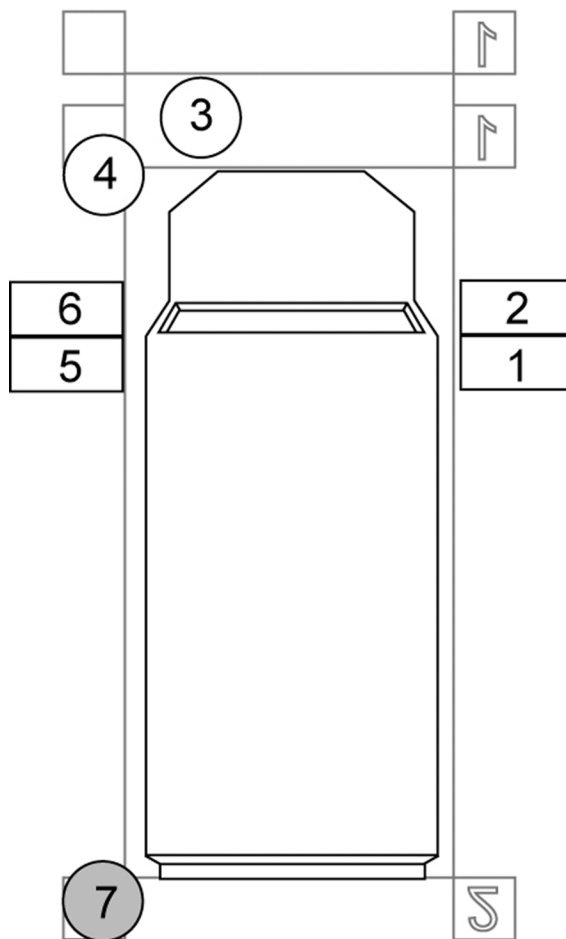

Exhibit A-2.7

Mirror Adjustment Station 7



Pot-lid mirror 7 is used in conjunction with mirror number 6 on the upper left corner of the LLV or FFV. Adjust so the driver can see the squares containing the numbers 2 and 3, the rear white line of the station, and the rear bumper.

Exhibit A-3.1

Mirror Adjustment Station: Activity 1

Activity: Mirror Coverage to the Left-Hand Side of the Vehicle

1. The student adjusts every mirror. While the vehicle is still parked in the MAS, the student sits in the driver's seat while the instructor stands just behind the left-hand door frame out of the driver's direct view. The student driver confirms observing the instructor in the left-side pot-lid, convex, and flat mirrors.
2. The instructor walks slowly to the left, at a right angle to the vehicle. Instructor tells the student to tap the horn and dismount properly when the student can no longer see the instructor in any of the mirrors.

Student learns:

1. What can be seen using the mirrors on the left-hand side of the vehicle.
2. Why it is important to adjust the mirrors properly every time before operating the vehicle.

Student Behaviors Desired and Observed:

1. The DSI observes the student:
2. Adjusting every mirror properly.
3. Using mirrors and noticing the instructor moving through and out of mirrors.
4. Tapping the horn when the instructor cannot be seen in the mirrors.
5. Dismounting from and securing the vehicle properly.

After dismounting properly, the student is able to describe the use, range, functionality, and capability of vehicle mirrors.

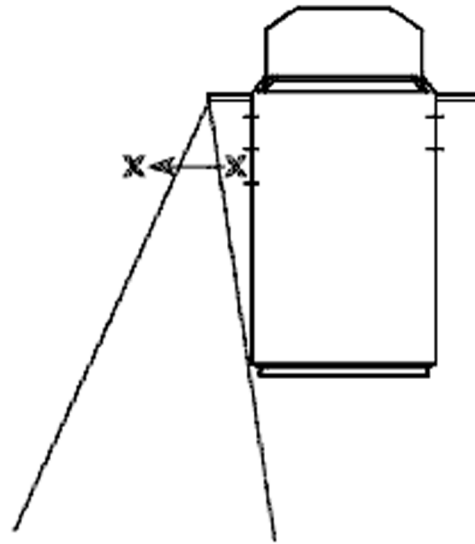

Exhibit A-3.2

Mirror Adjustment Station: Activity 2

Activity: Mirror Coverage Behind the Vehicle

1. The student adjusts every mirror. While the vehicle is still parked in the MAS, the student sits in the driver's seat while the instructor stands directly behind the vehicle so as to be seen in the rear pot-lid mirror. The student driver confirms observing the instructor in the rear, pot-lid mirror.
2. The instructor steps back, out of view of the rear pot-lid mirror, and walks slowly, straight back from the vehicle. Instructor tells the student to tap the horn and dismount properly when the student can see the instructor in both the left and right side mirrors.

Student learns:

1. What can be seen behind the vehicle when using mirrors.
2. Why it is important to adjust the mirrors properly every time before operating the vehicle.

Student Behaviors Desired and Observed:

The DSI observes the student:

1. Adjusting every mirror properly.
2. Using mirrors and noticing the instructor moving in and out of mirrors.
3. Tapping the horn when the instructor can be seen in both the left- and right-hand side mirrors.
4. Dismounting from and securing the vehicle properly.

After dismounting properly, the student is able to describe the use, range, functionality, and capability of vehicle mirrors.

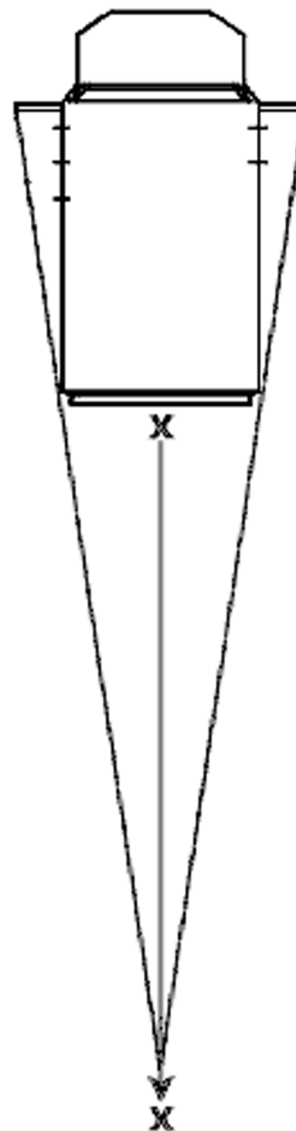

This page intentionally left blank

Appendix B

Controlled Driving Skills Course

Appendix B provides an introduction to the controlled driving skills course. It covers the purpose of the course, the role of the Driving Safety Instructor (DSI), and the equipment needed, and provides instructions for conducting the course. This appendix is used for training purposes.

Introduction

The Postal Service has developed two skills courses to replicate driving conditions specific to the Postal Service vehicles and situations that new drivers will experience when they arrive at their duty stations. The courses are:

1. *Delivery Skills Course* — for right-hand-drive (RHD) Postal Service delivery vehicles.
2. *Large-Truck Skills Course* — for vehicles 2 tons and up and vehicles that require commercial driver's licenses (CDLs).

[Exhibit B-1](#) illustrates the various components of the driving skills course. (The mirror station shown in the exhibit is part of vehicle familiarization, not controlled driving training.)

Purpose

The delivery skills course helps the new driver learn how to operate an RHD Postal Service vehicle safely and properly. The course is designed to give student drivers the opportunity to:

1. Have as much time and practice behind the wheel as possible.
2. Take the skills learned in the classroom and apply them to actual situations in a controlled driving environment.
3. Learn by doing rather than merely observing.

The DSI does not demonstrate tasks, but instead instructs the student in how to navigate a station and perform the tasks associated with that station. The DSI demonstrates a station task only when the student driver has difficulty understanding and applying instructions.

Overview

The delivery skills course contains seven stations (five required and two optional), including some with multiple tasks. Other stations may be added to demonstrate local driving situations. To add stations, the DSI consults with the safety manager to develop them, incorporating elements based on local conditions and accident data.

The delivery skills course is designed to have multiple instructors and drivers on the course at one time, as determined by the DSI. The Manager, Safety (District) will make all final determinations.

The large-truck skills course contains five required stations and multiple tasks.

Exhibit B-1
Postal Service Controlled Driving Skills Course

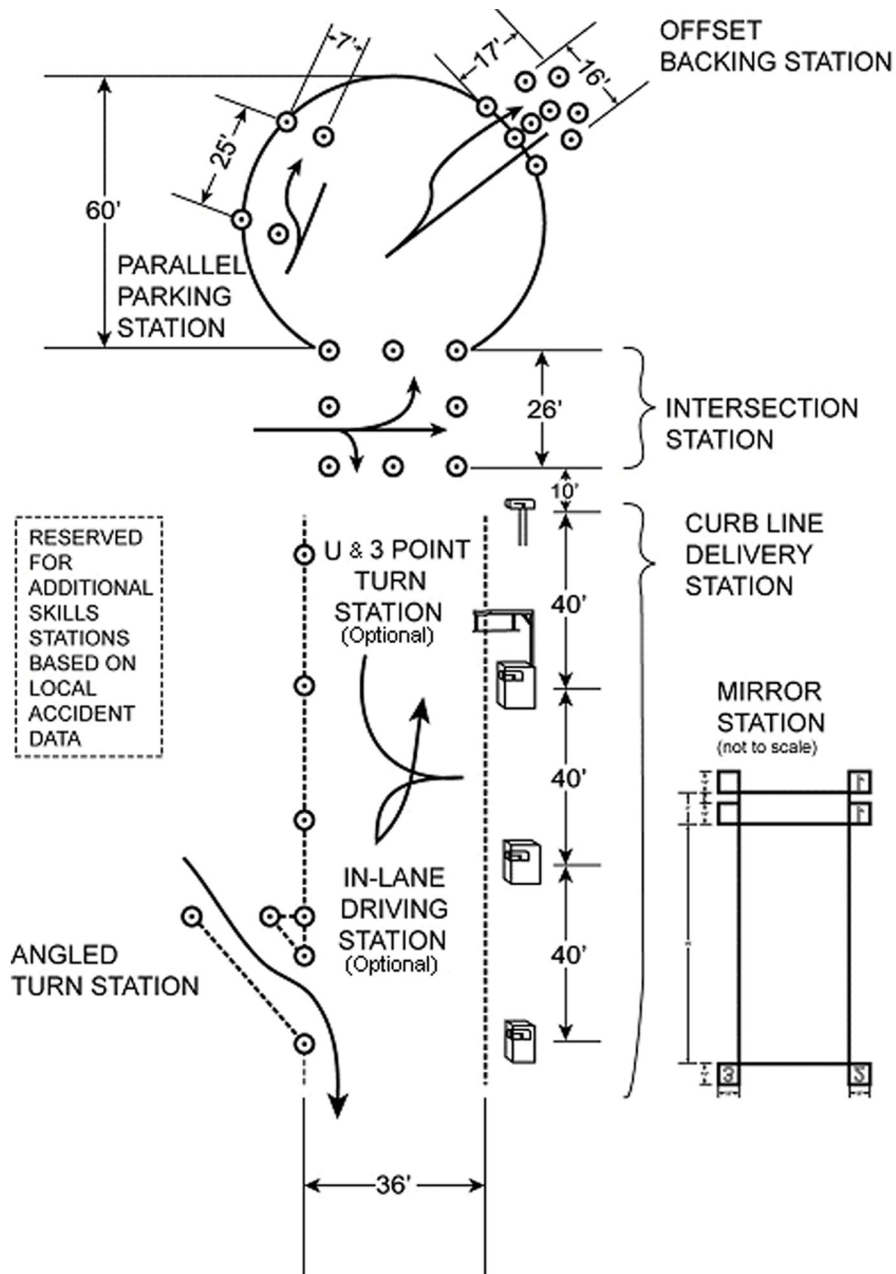

Equipment Needed

[Exhibit B-2](#) lists the equipment and approximate number of pieces needed for the delivery skills and the large-truck skills courses.

Exhibit B-2

Equipment Needed for Skills Courses (required and optional stations)

| |
|---|
| Delivery Skills Course |
| 38 cones |
| 4 test mail bundles (letters and flats) |
| 1 stop sign |
| 1 mock registered letter |
| 4 mail boxes (varying heights) |
| Large-Truck Skills Course |
| 24–74 cones |

Street Practice Driving

Controlled driving on the skills courses does not include time for street practice driving. After an individual completes the delivery skills course or the large-truck skills course, at least 45 minutes of controlled driving on the street is required for each type of vehicle. For CDL operators the 45 minutes of controlled driving includes a 15-minute, pre-drive safety check.

Role of the Driving Safety Instructor

The role of the DSI is to:

1. Assist student drivers to complete the delivery skills course *successfully*.
2. Ensure that CDL drivers have the skill sets needed to *pass* each station on the skills course.

During controlled driving on the delivery skills course, the DSI will:

1. Tell students that when they complete the skills course, they will take the end-of-training, RHD Privilege Certification in an LLV. Students who do not complete the delivery skills course will not take the end-of-training certification.
2. Tell students that they must rely on skill sets learned in the classroom to complete the skills course successfully.
3. Explain the layout of each station and expectations for its use.
4. Explain the purpose of each station on the skills course.
5. Provide minimal instruction on the tasks to be performed at each station (but the DSI will not provide instruction on the behaviors desired).
6. Observe students.
7. Allow student drivers to make mistakes.
8. Correct students based on their performance of the behaviors desired at each station and for each task.
9. Encourage and answer questions about each station.
10. Challenge student drivers to complete each task safely and quickly.

Student drivers must understand what constitutes a motor vehicle accident in the Postal Service. The DSI must inform student drivers of the following:

1. A *motor vehicle accident* is defined by the Postal Service as an accident with a motor vehicle that results in:
 - a. Any kind of personal injury.
 - b. Damage to property of \$1.00 or more.
2. Postal Service drivers are required to notify their supervisors whenever they are involved in a motor vehicle accident.

Time Allotted for Each Course

1. Controlled driving training on the delivery skills course:
 - a. Each student driver has a minimum of 3 hours and maximum of 3½ hours to complete controlled driving training on the delivery skills course. **Between the minimum 3 and maximum 3½ hours, only the student driver may terminate training.**
 - b. The DSI *must* terminate the course after the maximum allotted time of 3½ hours has been reached.
2. Controlled driving training on the large-truck skills course stations: Each student has a maximum of 3 hours to complete the course.

Time Allotted for Specific Stations – Delivery Skills Course

Although the maximum time allotted for the entire course is 3½ hours, there is no specific time allotment for each station. This gives the DSI flexibility to adjust station time based on local driving requirements. For example, in some parts of the country curbside delivery is not a major requirement for new drivers, so the DSI could reduce the time spent at the station. (However, the DSI could also decide not to reduce time at the curbside delivery station because of the skills it develops in handling vehicles and dealing with vehicle clearances.)

Instructions for Specific Stations – Delivery Skills Course

For each station, DSIs will tell student drivers the following:

1. *Parallel Park Station*. Skill sets that students gain at this station will help them to learn about vehicle clearances, use of mirrors, and vehicle pivot points.
2. *U-Turn and 3-Point-Turn Station (Optional)*. Inform students of the following:
 - a. State department of motor vehicles rules about making U-turns.
 - b. Skill sets they gain from this exercise will assist them to make U-turns properly (where permissible) and in accordance with state regulations.
 - c. Many Postal Service delivery routes require the ability to make U-turns and 3-point turns. Make these turns *only* at approved locations shown on the delivery route map.
3. *Angled-Turn Station*. Skill sets students gain from this exercise will help them to identify blind spots and position RHD vehicles properly when they merge with traffic at angled intersections.

4. *Offset Backing Station.* Skill sets students gain from this exercise will help them to identify the pivot point of the vehicle, use mirrors, back up to docks, and back into parking spaces.
5. *Intersection Station.* Student drivers will employ the skills learned during classroom training. Students should know the following:
 - a. Failure-to-yield accidents are very common in the Postal Service (either the Postal Service driver or a member of the public fails to yield).
 - b. Failure-to-yield accidents are dangerous; they frequently cause injuries.
 - c. Students must understand why it is necessary to do a “head bob” when looking left out of an LLV or FFV.
6. *Curbside Delivery Station.* Tell students that:
 - a. Skill sets gained from this exercise will help students learn about vehicle clearances (horizontal and vertical) and the handling characteristics of delivery vehicles.
 - b. Several tasks must be completed at this station; the tasks simulate real curb-box delivery scenarios they may encounter on the job.
7. *In-Lane Station (Optional).* Skill sets gained from this exercise will help them to position and maintain the vehicle within the proper lane while driving.

This page intentionally left blank

Appendix C

Delivery Skills Course

Appendix C describes the delivery skills course for the Postal Service's right-hand-drive (RHD) delivery vehicles. It includes tasks, diagrams, and instructions for conducting training activities. While the stations and activities may be performed in any order, we suggest conducting the curbside delivery station and its activities last. The delivery course skills stations are listed below:

1. Intersection (six tasks).
2. Offset backing.
3. Angled right turn.
4. U-turn and 3-point turn (optional).
5. Parallel parking.
6. In-lane driving (optional).
7. Curbside delivery (seven tasks).

Exhibit C-1.1

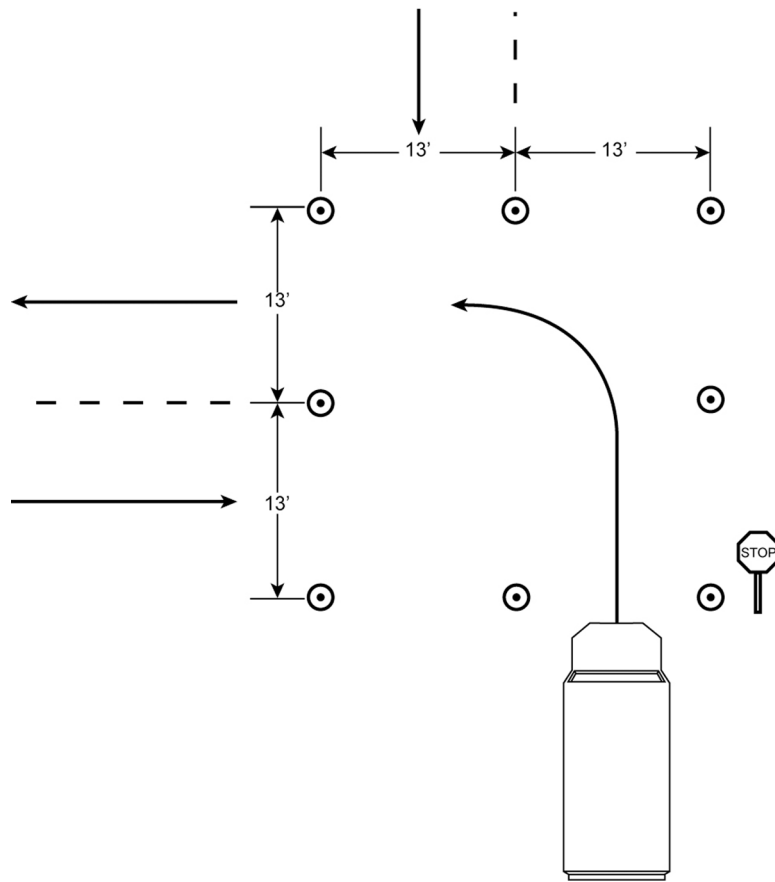
Intersection Station: Task 1*Activity: Stop, Then Turn Left at Intersection*

Skill sets gained from this station and its various tasks will help the student to navigate an intersection safely.

Inform students that failure-to-yield accidents are very common in the Postal Service (either the Postal Service driver or a member of the public fails to yield). Failure-to-yield accidents are dangerous and frequently cause injuries.

Help students to understand why it is necessary to do a “head bob” when looking left out of an LLV or FFV.

Student Behaviors Desired and Observed:

1. Applies lap and shoulder belts and makes sure the door is closed before moving vehicle.
2. Comes to a complete stop behind the stop sign.
3. Looks left, right, left before entering intersection.
4. Uses “head bob” when looking left to see around left-hand-side mirrors and supports.
5. Proceeds into intersection — checking mirrors.
6. Squares up turn and does not cut corner.
7. Completes task in a timely manner without striking any cones.

Exhibit C-1.2

Intersection Station: Task 2

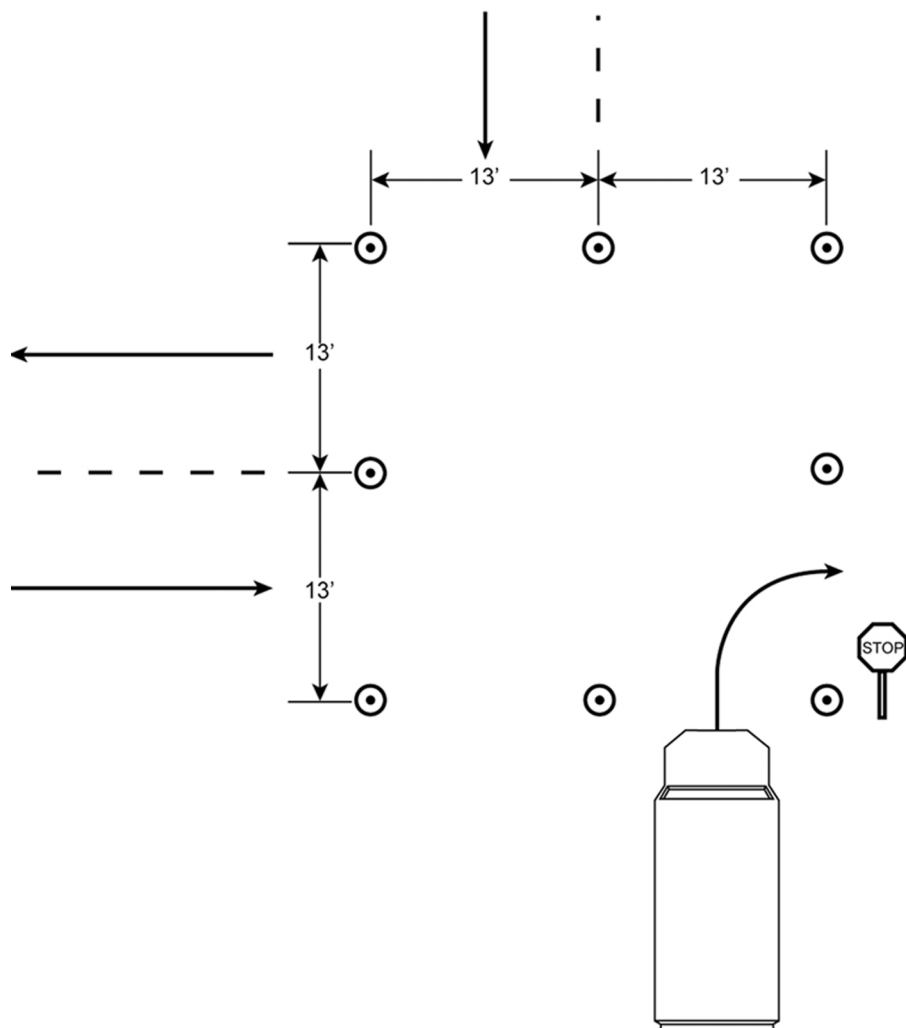

Activity: Stop, Then Turn Right at Intersection

Student Behaviors Desired and Observed:

1. Applies lap and shoulder belts and makes sure the door is closed before moving vehicle.
2. Signals before arriving at intersection.
3. Comes to a complete stop behind the stop sign.
4. Looks left, right, left before entering intersection.
5. Uses “head bob” when looking left.
6. Proceeds into intersection — checking mirrors.
7. Squares up turn and does not cut corner.
8. Completes task in a timely manner without striking any cones.

Exhibit C-1.3

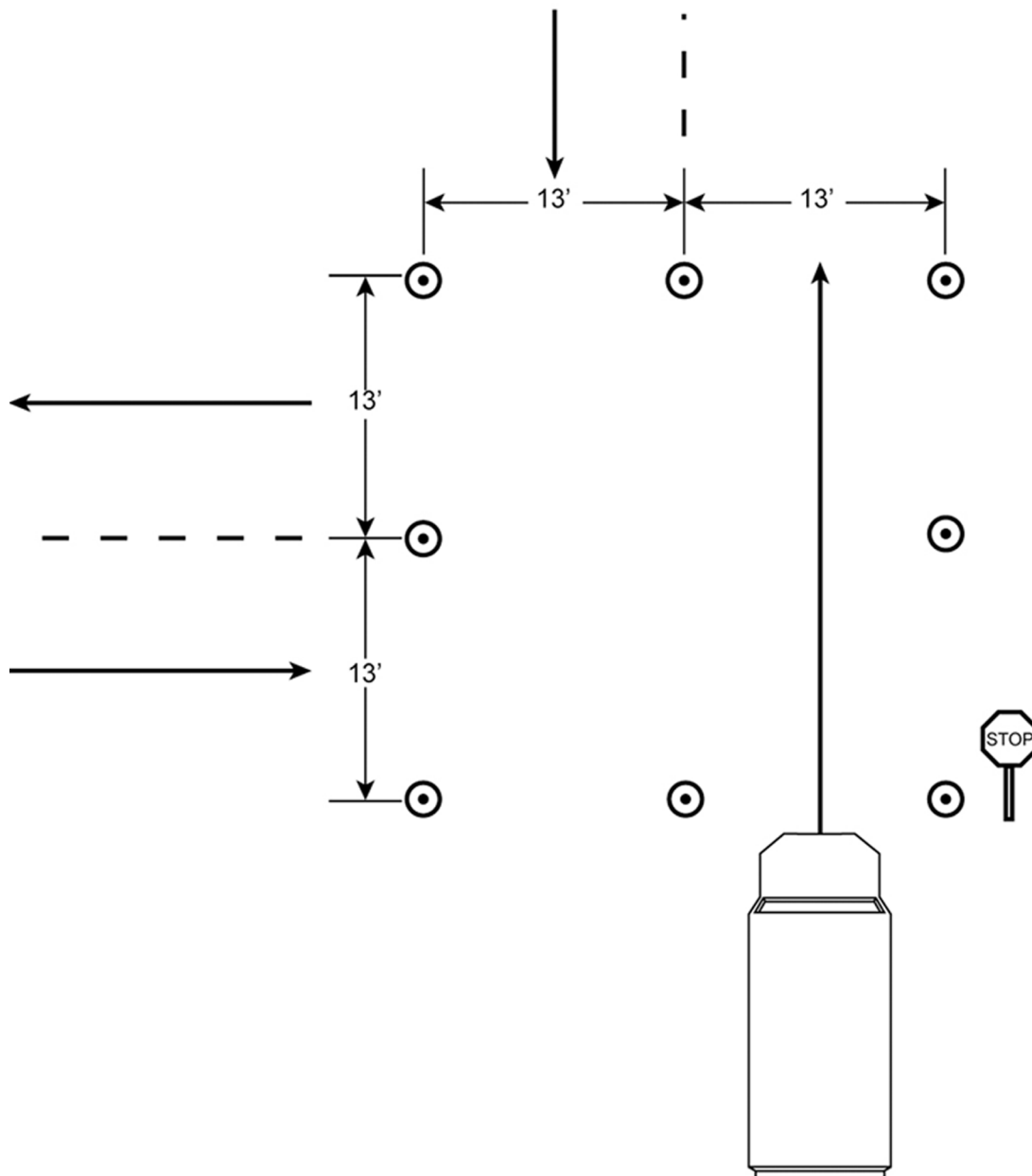
Intersection Station: Task 3

Activity: Stop, Then Go Straight Ahead Through Intersection

Student Behaviors Desired and Observed:

1. Applies lap and shoulder belts and makes sure the door is closed before moving vehicle.
2. Comes to a complete stop behind the stop sign.
3. Looks left, right, left before entering intersection.
4. Uses "head bob" when looking left.
5. Periodically checks mirrors before, during, and when leaving intersection.
6. Completes task in a timely manner without striking any cones.

Exhibit C-1.4

Intersection Station: Task 4

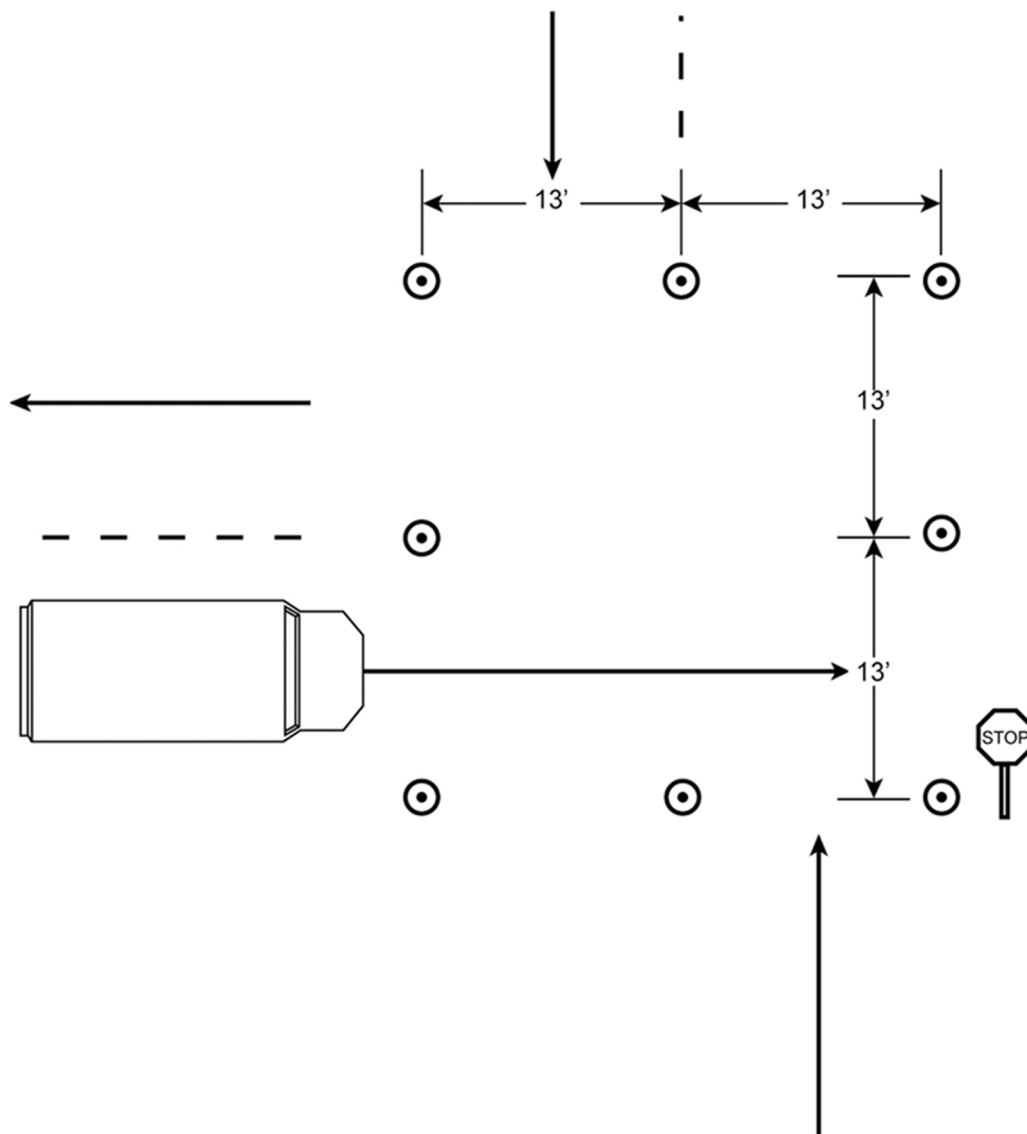

Activity: Go Straight Ahead Through Intersection (No Stop Sign)

Student Behaviors Desired and Observed:

1. Applies lap and shoulder belts and makes sure the door is closed before moving vehicle.
2. Slows down when approaching intersection.
3. Looks left, right, left before entering intersection.
4. Uses "head bob" when looking left.
5. Periodically checks mirrors before, during, and when leaving intersection.
6. Completes task in a timely manner without striking any cones.

Exhibit C-1.5

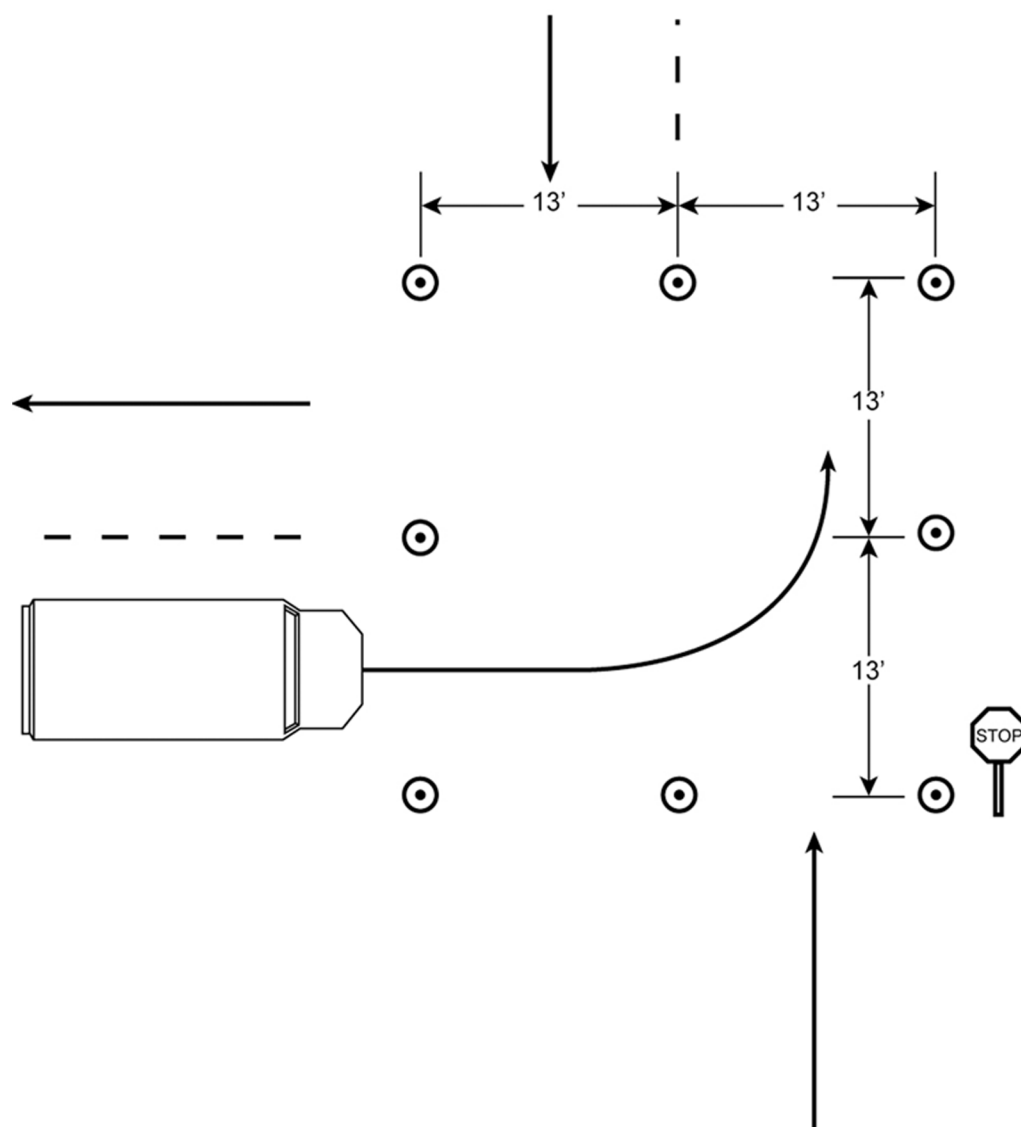
Intersection Station: Task 5

Activity: Go Through Intersection, Turn Left (No Stop Sign)

Student Behaviors Desired and Observed:

1. Applies lap and shoulder belts and makes sure the door is closed before moving vehicle.
2. Signals before approaching intersection.
3. Slows down and positions vehicle in anticipation of turn while approaching intersection.
4. Looks left, right, left before entering intersection.
5. Uses "head bob" when looking left.
6. Periodically checks mirrors before, during, and when leaving intersection.
7. Squares up turn and does not cut corner.
8. Completes task in a timely manner without striking any cones.

Exhibit C-1.6

Intersection Station: Task 6

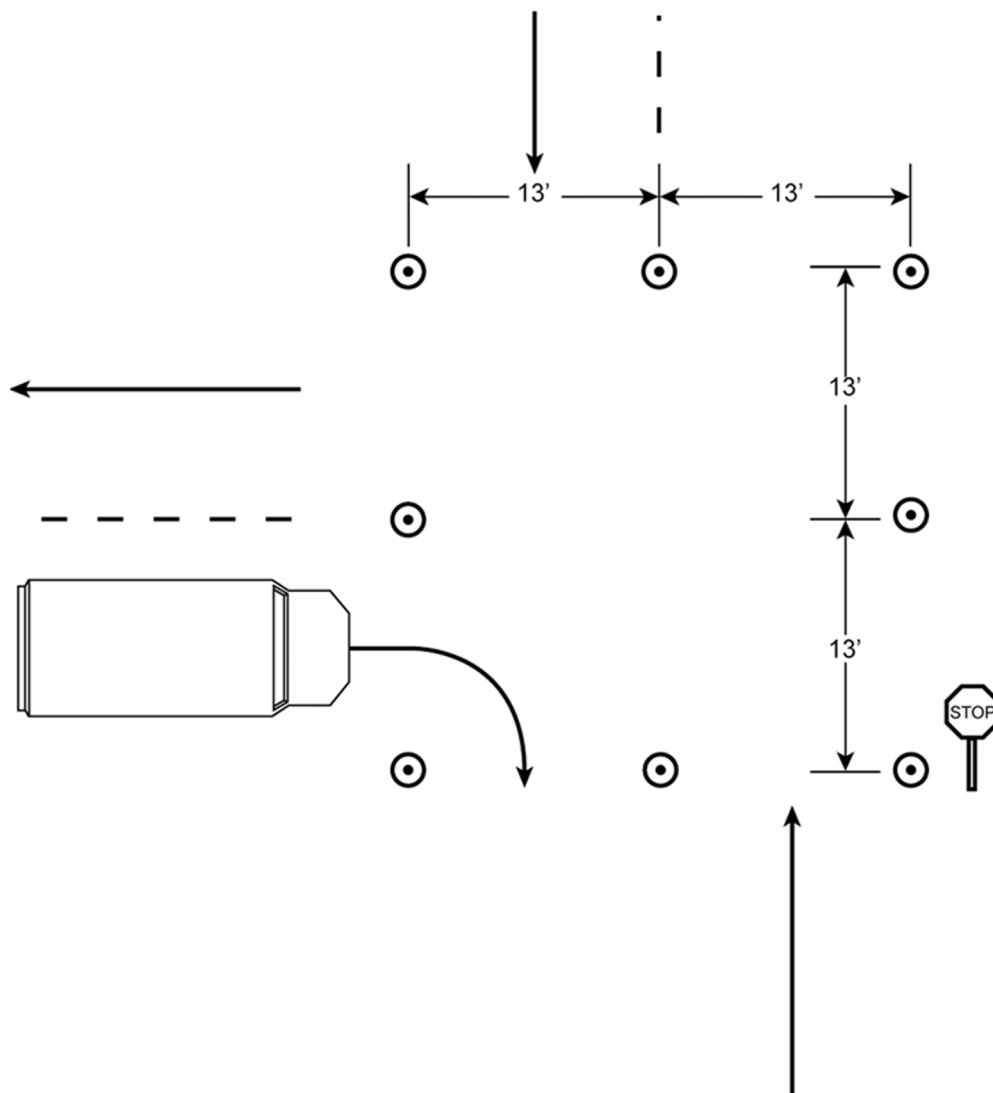

Activity: Go Through Intersection, Turn Right (No Stop Sign)

Student Behaviors Desired and Observed:

1. Applies lap and shoulder belts and makes sure the door is closed before moving vehicle.
2. Signals before approaching intersection.
3. Slows down and positions vehicle in anticipation of turn while approaching intersection.
4. Looks left, right, left before entering intersection.
5. Uses "head bob" when looking left.
6. Periodically checks mirrors before, during, and when leaving intersection.
7. Squares up turn and does not cut corner.
8. Completes task in a timely manner without striking any cones.

Exhibit C-2

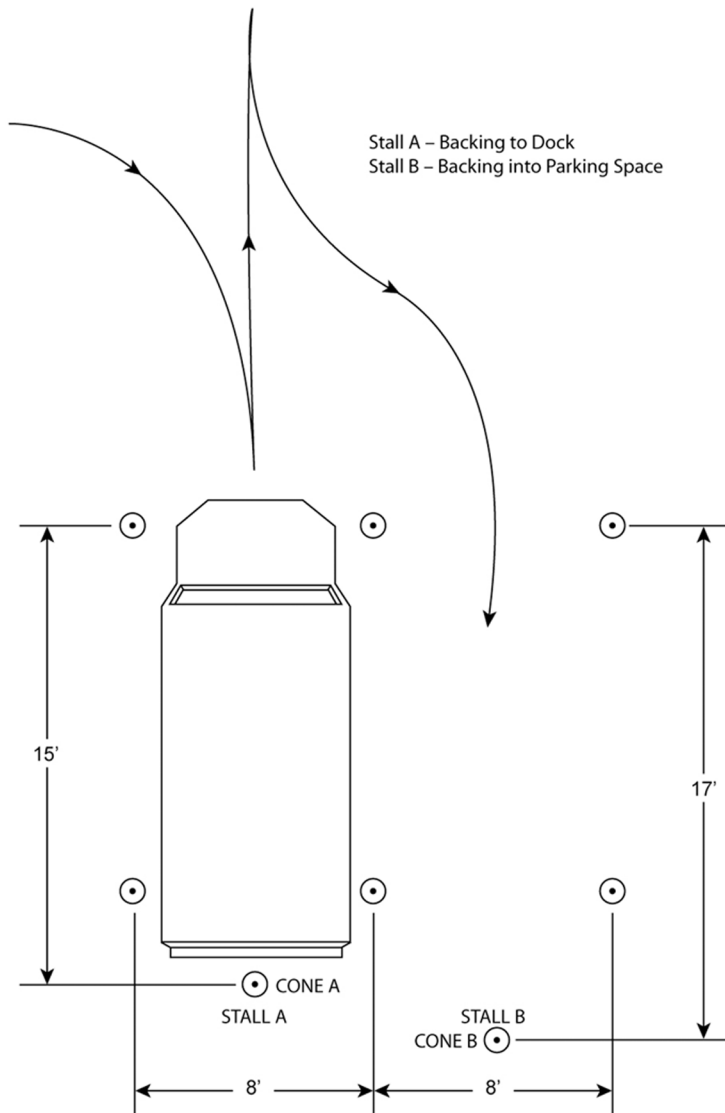
Offset Backing Station*Activity: Back Up at an Angle (Offset Backing)*

Skill sets gained from this exercise, including identifying the vehicle's pivot point and using mirrors, will enable students to safely back into docks and into parking spaces.

Student Behaviors Desired and Observed:

1. Applies lap and shoulder belts and makes sure the door is closed before moving vehicle.
2. Pulls forward approximately 30 feet from stall when moving from stall A to stall B.
3. Uses mirrors to back up.
4. Uses rear vision camera where applicable.
5. Sounds horn when backing up (optional).
6. Makes sure the rear bumper is within 1 foot of cone A or cone B.
7. Centers vehicle in each stall.
8. Exits properly and secures vehicle after backing into each stall.
9. Completes tasks of properly backing into stalls in less than 2 minutes without hitting any cones.

Exhibit C-3
Angled-Right-Turn Station

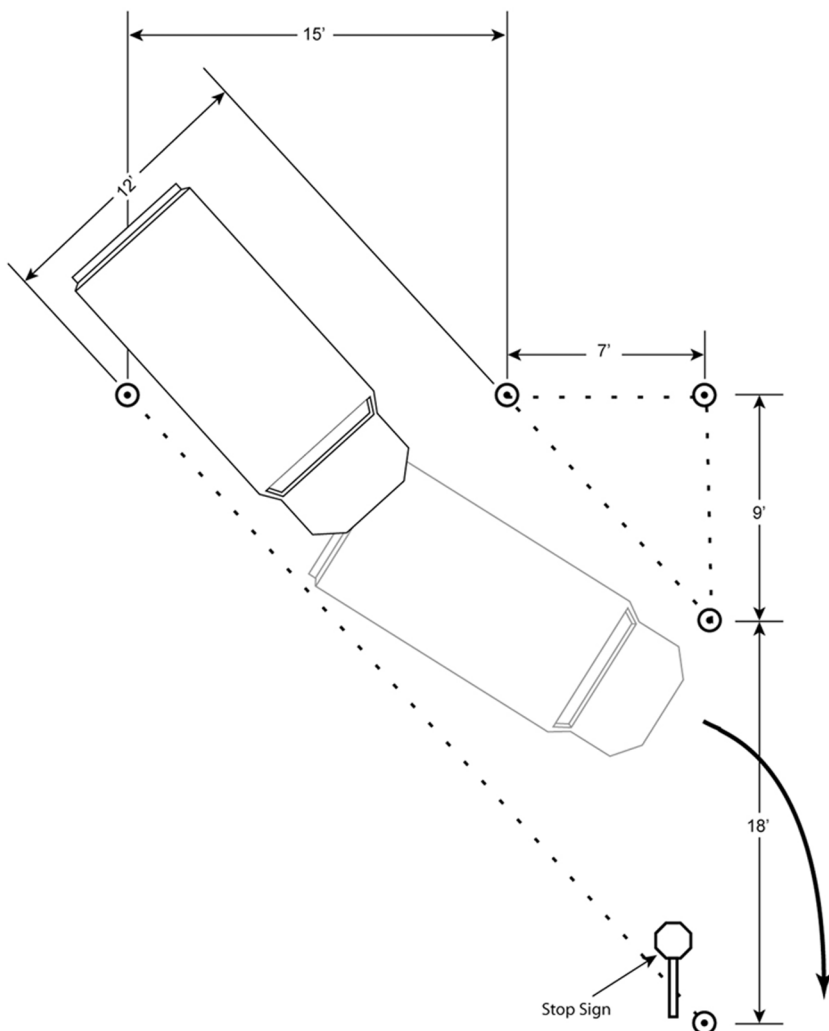

Activity: Turn Right at an Angled Intersection

Skill sets gained from this exercise will help students identify blind spots and position RHD vehicles properly when merging with traffic at angled intersections.

Student Behaviors Desired and Observed:

1. Applies lap and shoulder belts and makes sure the door is closed before moving vehicle.
2. Activates right-turn signal when approaching angled intersection.
3. Anticipates turn and squares up vehicle upon approaching stop sign so driver can see farther to left.
4. Comes to a complete stop behind the stop sign.
5. Looks left, right, left before entering angled intersection.
6. Uses "head bob" when looking left.
7. Demonstrates safe, smooth, and controlled turns.

Exhibit C-4

U-Turn and 3-Point Turn Station (Optional)*Activity: U-Turn and 3-Point Turn*

This exercise helps students learn the turning radius of delivery vehicles.

Skills gained from this exercise will assist students to make U-turns and 3-point turns properly and in accordance with state regulations.

Ask students to make a U-turn from the right curb, and then attempt another U-turn from the left lane. Students should be able to complete a U-turn from the right curb without backing up. However, when attempting to make a U-turn from the left lane, students will discover that a 3-point turn is necessary.

Note: The DSI must:

1. Instruct students regarding Postal Service requirements and local and state motor vehicle laws for U-turns and 3-point turns.
2. Remind students that U-turns and 3-point turns must be performed legally and only at previously approved locations.

Student Behaviors Desired and Observed:

1. Applies lap and shoulder belts and makes sure the door is closed before moving vehicle.
2. Activates turn signal before initiating turn.
3. Checks mirrors before starting and while making the turn.
4. Checks mirrors after completing the turn.
5. Places the vehicle in the center of the lane going in the opposite direction when initiating U-turn from right curb.
6. Completes the U-turn without backing up and without striking any cones when initiating U-turn from right curb.
7. Completes the 3-point turn, backing up only once when initiating U-turn from left lane.

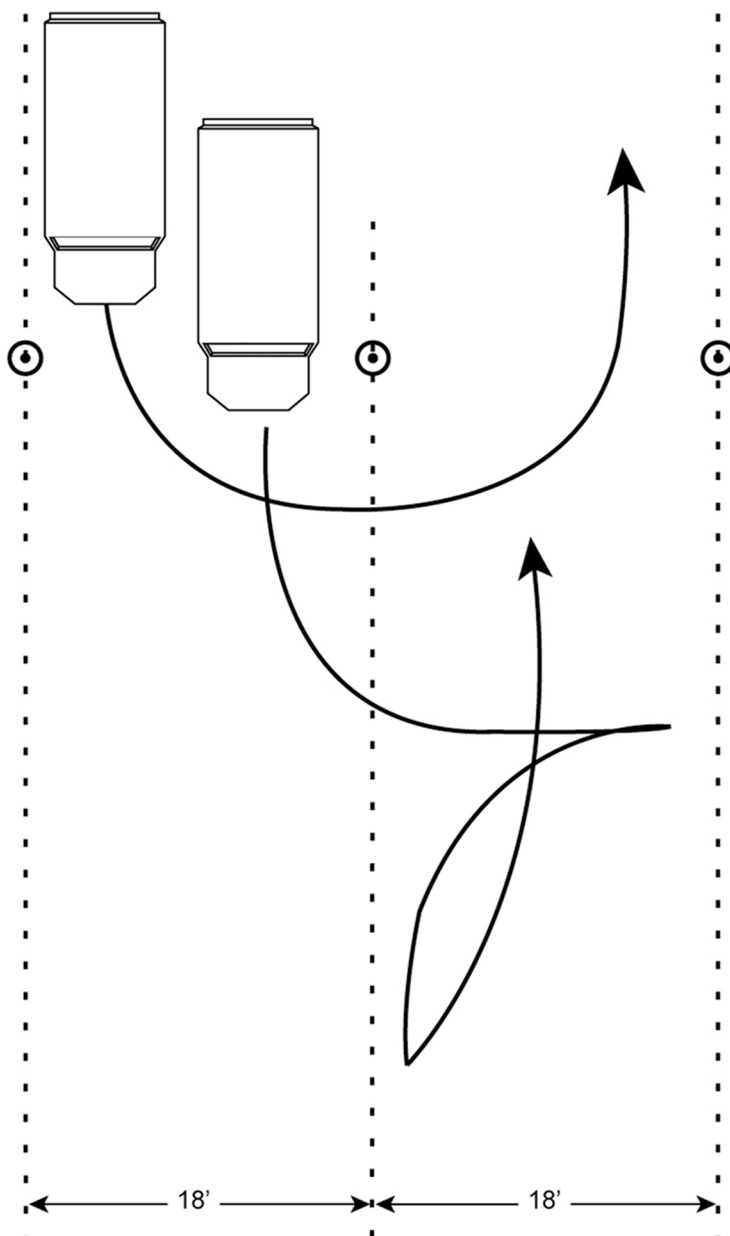
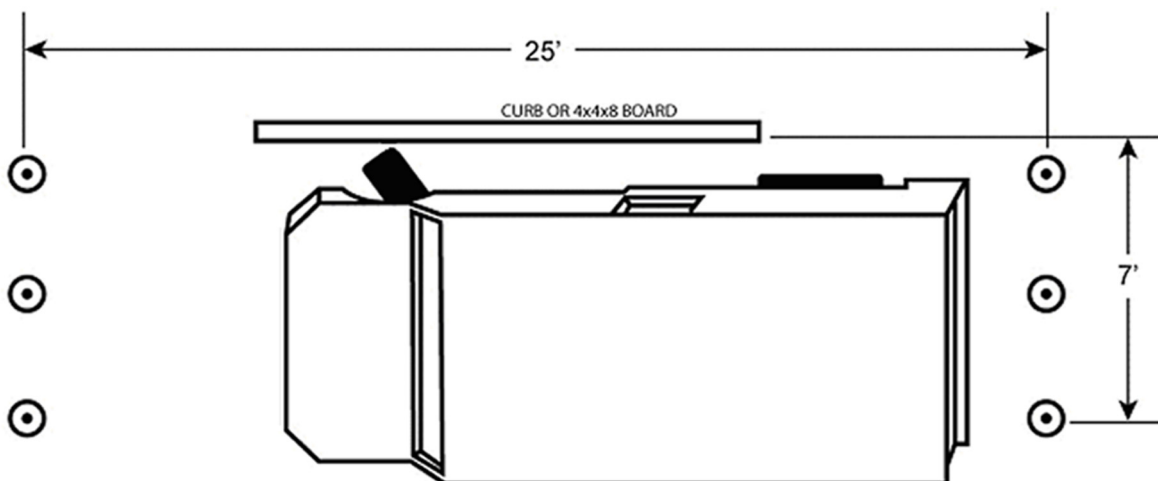

Exhibit C-5

Parallel Parking Station*Activity: Parallel Parking*

Skill sets that students gain at this station will help them to learn about vehicle clearances, use of mirrors, vehicle pivot points, and securing a vehicle properly. Unless required by local guidelines, the front tire does not have to touch the curb, just be turned toward it.

Note that this maneuver may also be done with the vehicle's left side toward the curb if local delivery conditions require it (e.g., on one-way streets).

Student Behaviors Desired and Observed:

1. Applies lap and shoulder belts and makes sure the door is closed before moving vehicle.
2. Centers vehicle within cones.
3. Curbs front wheels, tires turned toward the curb.
4. Makes sure back wheels are no more than 12 inches from curb.
5. Secures vehicle properly upon exiting.
6. Completes parallel parking successfully within 1 minute from start to finish.

Exhibit C-6

In-Lane Driving Station (Optional)

Activity: Keep Vehicle Within a Lane

Skill sets gained from this exercise will help students position and maintain the vehicle within the proper lane while driving.

Student Behaviors Desired and Observed:

1. Applies lap and shoulder belts and makes sure the door is closed before moving vehicle.
2. Keeps vehicle within lane while driving.

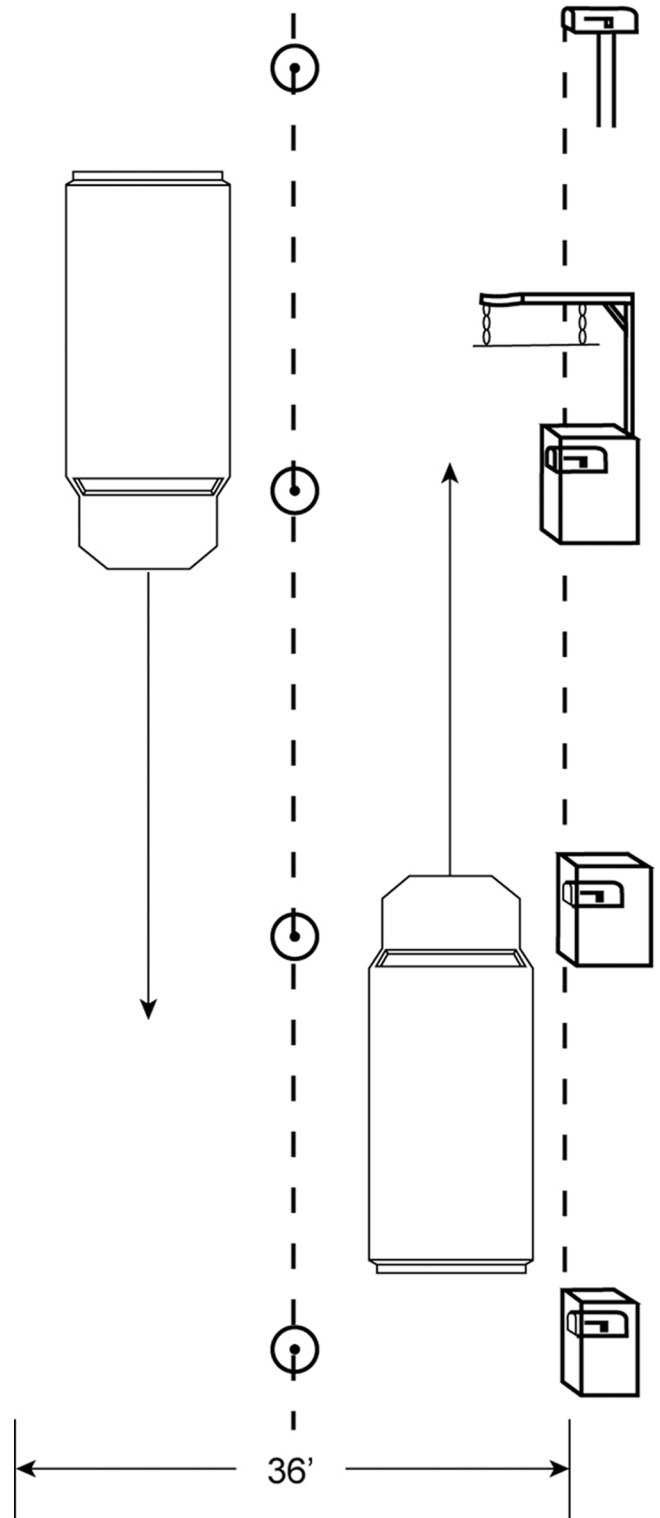

Exhibit C-7.1

Curbside Delivery: Task 1

Activity: Dry Run Without Box Obstructions and Without Mail

Skill sets gained at this station will help students learn about delivery vehicle handling clearances (horizontal and vertical).

Several tasks must be completed at this station. Each simulates real curb-box scenarios that students may encounter on the job.

For task 1, the station has a clear line of travel (no cones representing parked cars). Students drive down the line of boxes, stop at each box, and simulate a delivery (tapping the top of each box).

Student Behaviors Desired and Observed:

1. Applies lap and shoulder belts and makes sure the door is closed before moving vehicle.
2. Stops at delivery point close enough to comfortably simulate delivery to curb box (no extreme reaching or dismounting).
3. Turns to face front of vehicle before driving to the next delivery point.
4. Checks left mirrors before driving to the next delivery point.
5. Anticipates next delivery (plans ahead to deliver correctly to next box).
6. Delivers successfully at box D (48 inches high) without striking the vehicle's mirror or mirror brackets against the rural box or its support structure.
7. Uses turn signal after box D before leaving the right-hand curb and entering roadway.

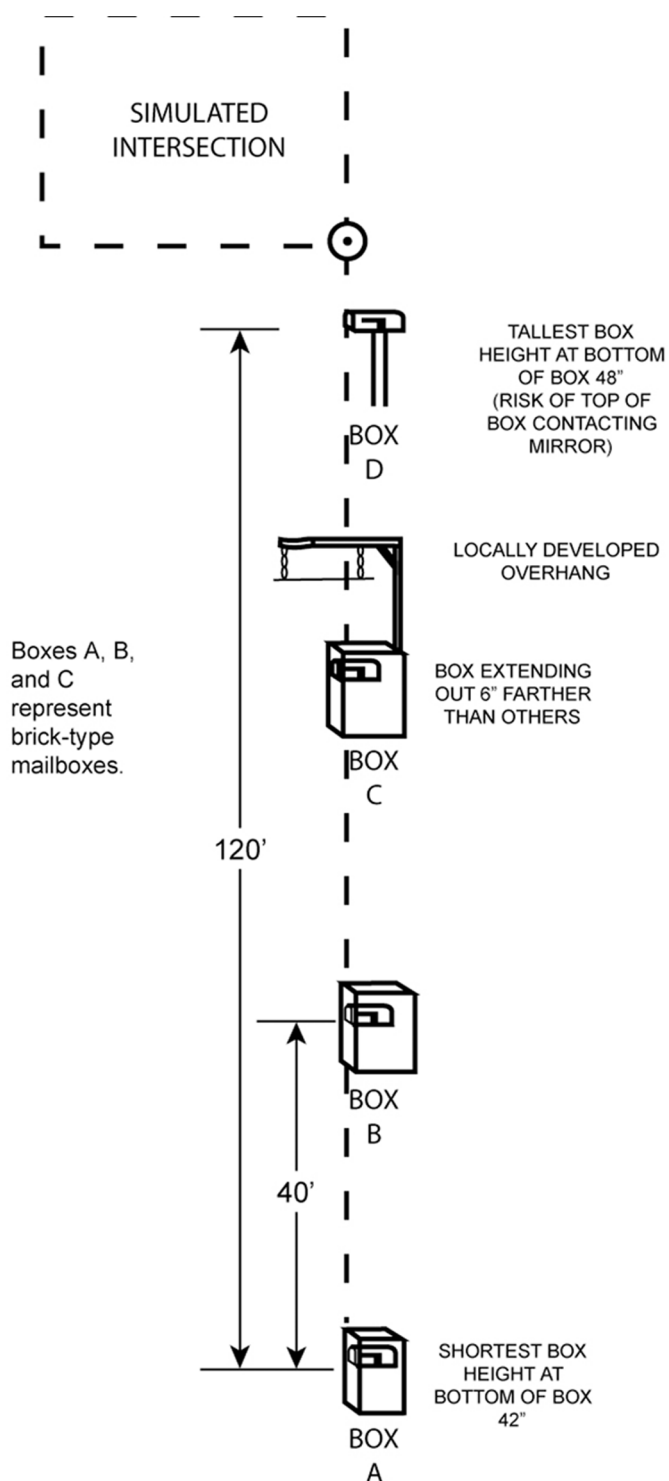

Exhibit C-7.2

Curbside Delivery: Task 2

Activity: Delivery With Obstructions and Without Mail

For task 2, an unobstructed delivery point at box B is added to the station. Cones are placed 20 feet in front of and 15 feet behind the delivery point box B to represent parked vehicles. The cones should be placed 5 feet from the curb. A delivery point that is obstructed, but not blocked, will allow the student to navigate the obstructions and make delivery from the vehicle.

Student Behaviors Desired and Observed:

1. Applies lap and shoulder belts and makes sure the door is closed before moving vehicle.
2. Anticipates obstructed delivery at box B and positions vehicle to accommodate delivery from vehicle without dismounting.
3. Checks left-hand mirror and signals before moving left to go around first cone prior to vehicle entering roadway.
4. Clears first cone successfully and has appropriate angle to box to safely facilitate delivery.
5. Simulates delivery to curb box comfortably and without abnormal or unsafe reaching.
6. Checks left-hand mirror and signals left before attempting to go around second cone.
7. Clears second cone successfully and aligns vehicle in anticipation of next delivery.
8. Signals before entering the roadway at box D.

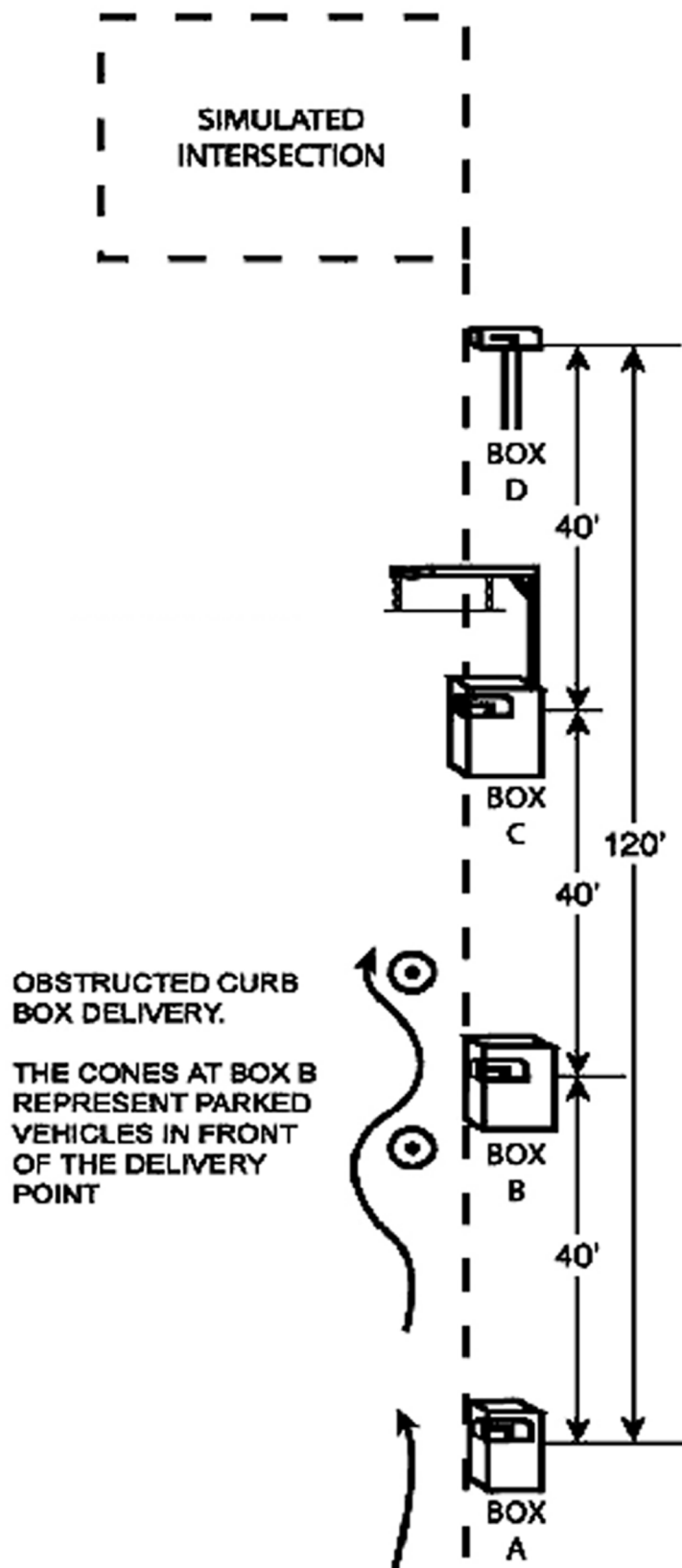

Exhibit C-7.3

Curbside Delivery: Task 3

Activity: Obstructed and Blocked Delivery Without Mail

Skill sets for task 3 will help the student to understand and recognize the difference between an obstructed and a blocked delivery. Additional skills sets will help the student to properly deliver mail at an obstructed or blocked delivery point.

For this task, the station continues to have an obstructed delivery point at box B. Cones are placed in front of and behind the delivery point to represent parked vehicles.

Added to the station is a blocked delivery point at box C. A cone is placed at the box to represent a parked vehicle. A delivery point that is blocked, rather than obstructed, will require the student to properly dismount the vehicle to make delivery.

Student Behaviors Desired and Observed:

1. Applies lap and shoulder belts and makes sure the door is closed before moving vehicle.
2. Delivers successfully to box B by going around obstacles carefully, without dismounting or striking any cones.
3. Anticipates delivery at box C and properly positions vehicle for a dismount that does not require a backing maneuver.
4. Exits and secures vehicle properly to simulate delivery at box C.
5. Upon return to vehicle, applies lap and shoulder belts and closes door before moving the vehicle.
6. Delivers mail successfully at each box without backing the vehicle or striking cones or mailboxes.
7. Signals before entering the roadway.

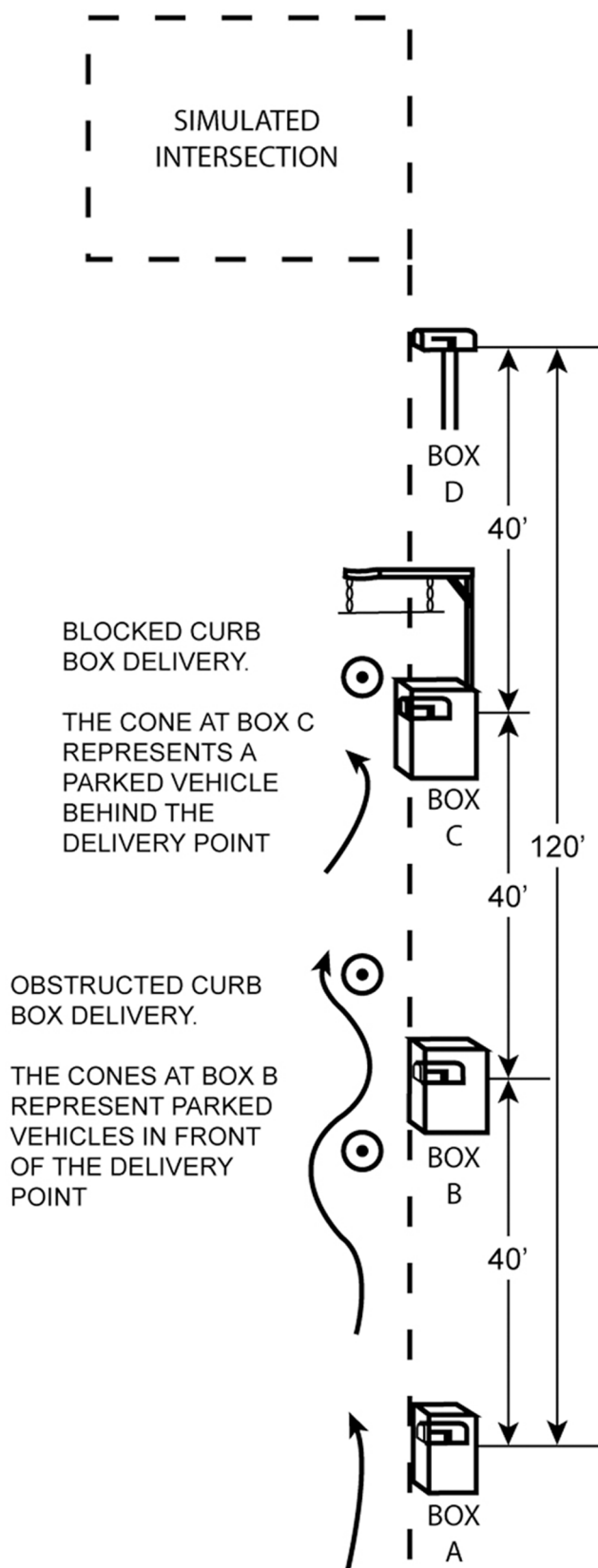

Exhibit C-7.4

Curbside Delivery: Task 4

Activity: Timed Delivery Without Mail

The setup for task 4 is the same as for task 3; however, a time factor added. The student driver must negotiate the station safely and properly in less than 3 minutes.

The station continues to have an obstructed delivery point at box B (cones placed in front of and behind the delivery point to represent parked vehicles) and a blocked delivery point at box C (a cone placed at the box).

Student Behaviors Desired and Observed:

1. Continues to demonstrate desired behaviors outlined in tasks 1–3.
2. Completes delivery successfully to all boxes at this station in less than 3 minutes.
3. Is ready to practice with mail at each delivery point.

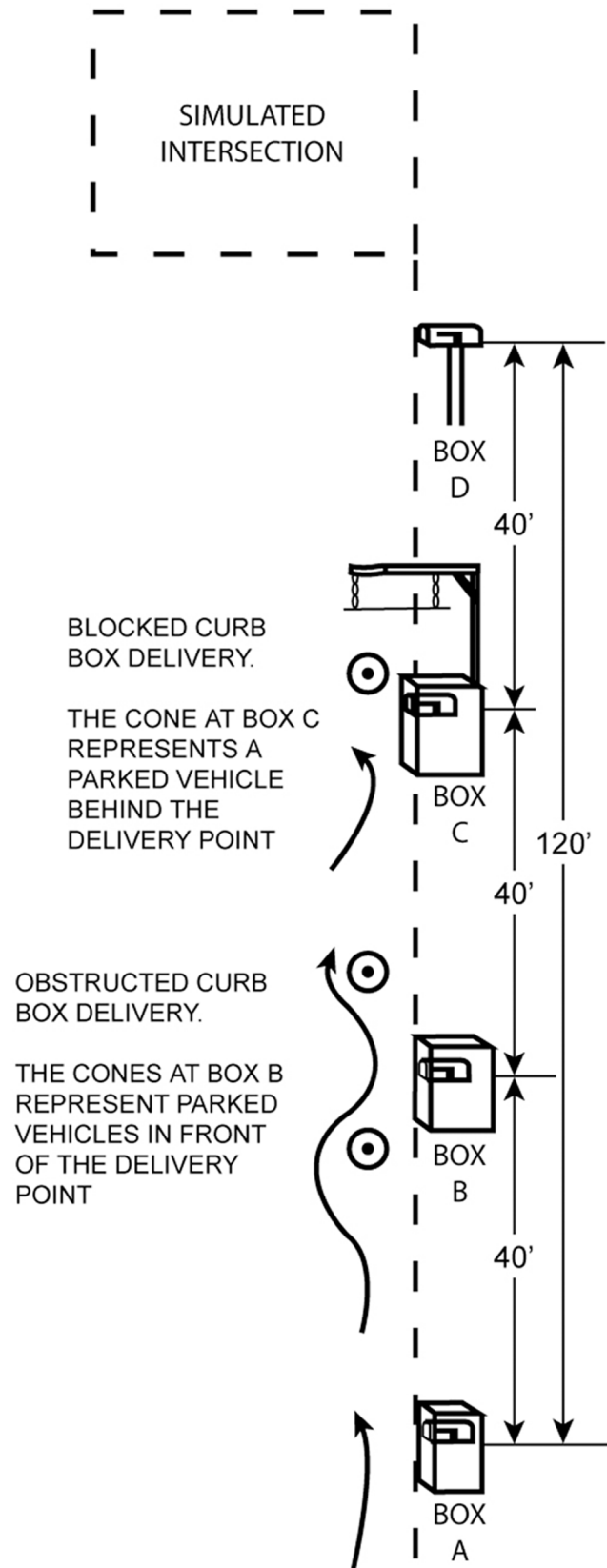

Exhibit C-7.5

Curbside Delivery: Task 5

Activity: Obstructed and Blocked Delivery With Mail

For task 5, students deliver mock mail to each of the boxes.

The station continues to have an obstructed delivery point at box B and a blocked delivery point at box C.

Student Behaviors Desired and Observed:

1. Continues to demonstrate desired behaviors outlined in tasks 1–3.
2. Does not hold or finger mail while the vehicle is moving.
3. Completes each delivery without striking cones or curb boxes.
4. Completes mail delivery to all 4 boxes in less than 3 minutes.

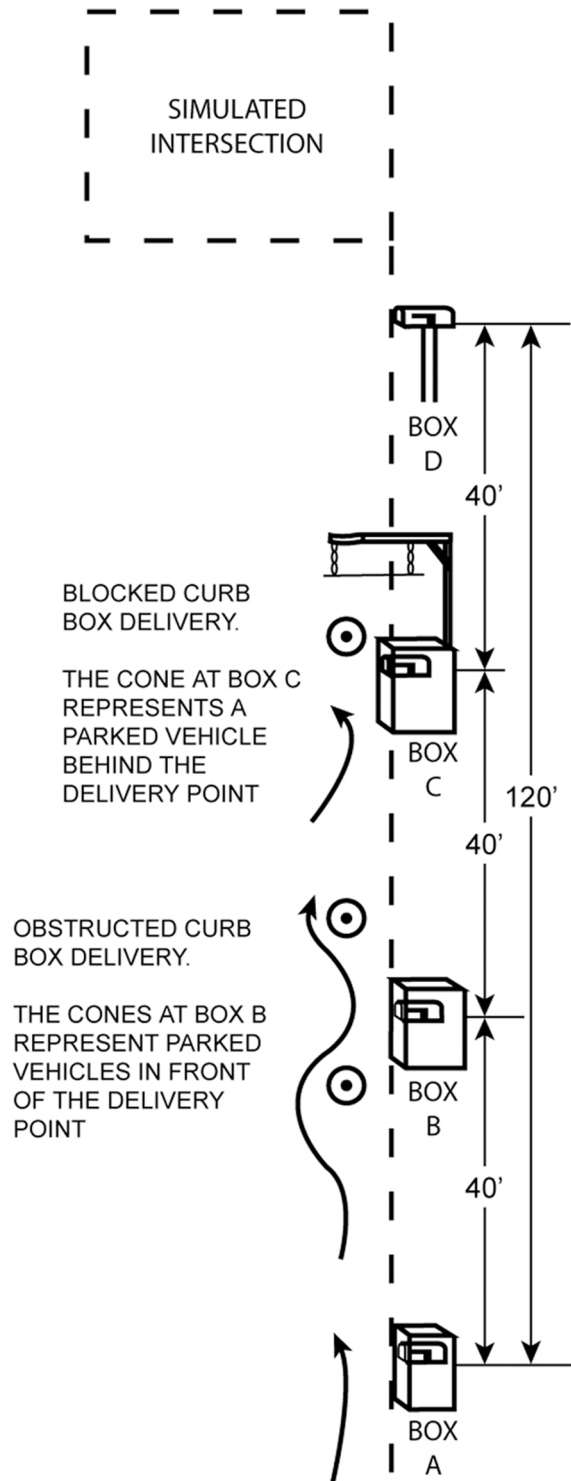

Exhibit C-7.6

Curbside Delivery: Task 6*Activity: Delivery With an Accountable Piece of Mail*

To successfully accomplish task 6, students must deliver a mock piece of Certified Mail™ to box properly.

Explain to student how to handle Certified Mail that requires a signature.

This is not a timed activity.

Student Behaviors Desired and Observed:

1. Positions vehicle properly for dismounting (close to curb and does not require backing up upon departure).
2. Does not hold or finger mail while vehicle is moving.
3. Secures vehicle properly upon exiting.
4. Handles piece of Certified Mail properly.
5. Inspects area around vehicle for children playing before entering vehicle.
6. Enters vehicle, applies lap and shoulder belts, and closes door.
7. Checks mirrors before moving the vehicle.
8. Signals before entering the roadway.

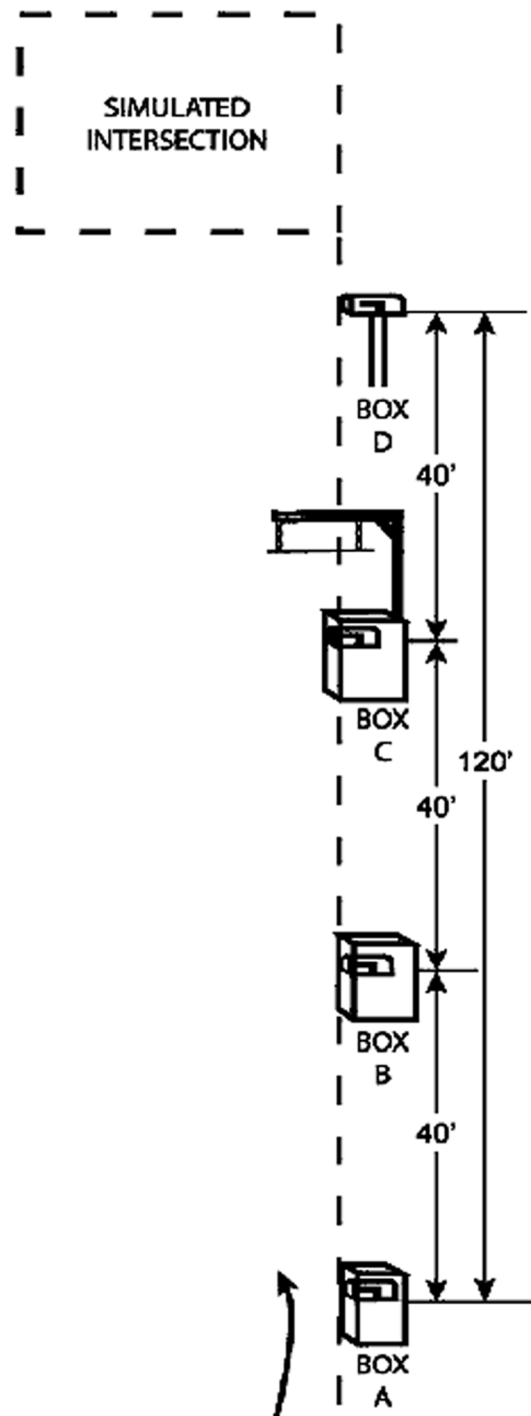

Exhibit C-7.7

Curbside Delivery: Task 7

Activity: Handle Out-of-Sequence Mail

Task 7 will teach the student to avoid backing up when encountering out-of-sequence mail.

For this task, out of the view of the student, arrange the mock mail so a piece is out of sequence. Place a piece of mail for box B with the mail for box C or D.

Student Behaviors Desired and Observed:

1. Avoids backing up to satisfy delivery of the out-of-sequence piece of mail.
2. Secures the vehicle properly upon dismount, walks back to box B, and makes delivery.
3. Before re-entering the vehicle, inspects area around vehicle for children playing.
4. Enters vehicle, applies lap and shoulder belt, and closes door.
5. Checks mirrors before moving vehicle.
6. Signals before entering the roadway.

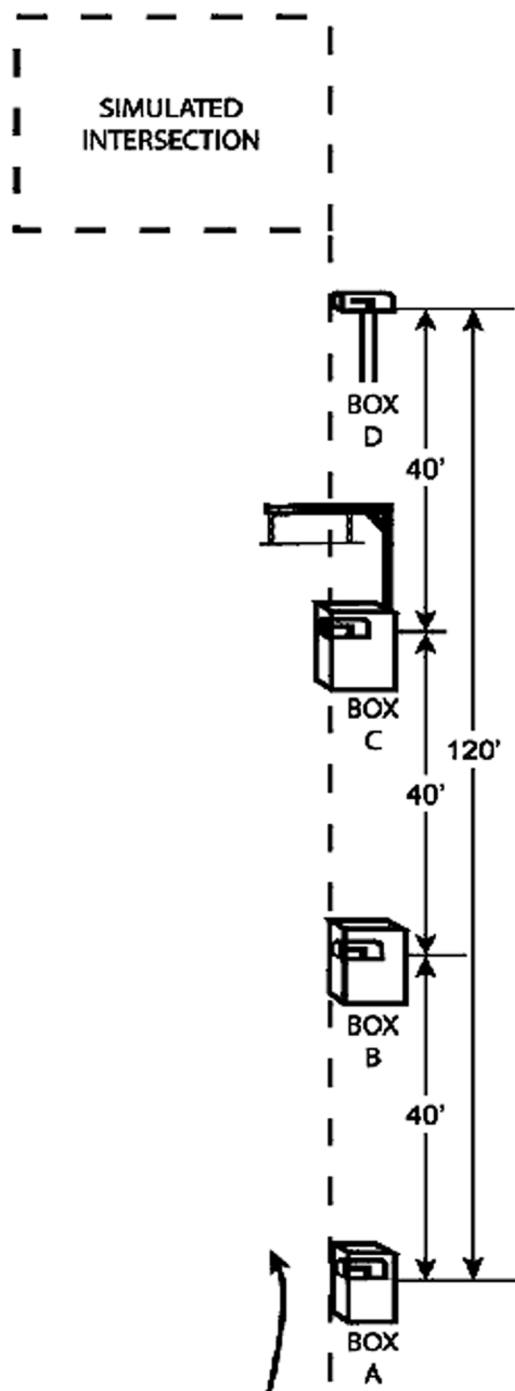

This page intentionally left blank

Appendix D

Large-Truck Skills Course

Appendix D lists the dimensions recommended for the large-truck skills course and provides diagrams and instructions for conducting activities at the following stations:

1. Rear-swing clearance (optional).
2. Forward, stop, straight-line backing.
3. Offset backing.
4. Alley and dock backing.
5. Parallel parking.

Exhibit D-1

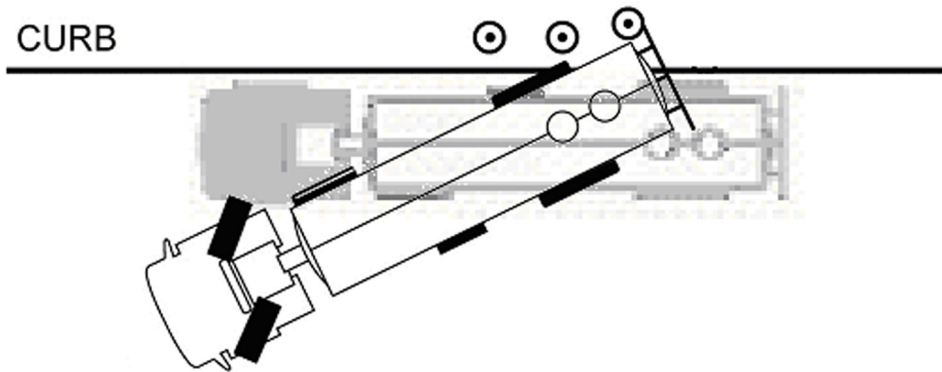
Rear-Swing Clearance Station

Purpose: To have the driver see how much the truck swings out (extends beyond the road) when he or she pulls away sharply from a curb or makes a sharp turn. This activity is intended to demonstrate the potential hazard to pedestrians and objects when the rear end of the vehicle swings.

Instructions:

Before starting this task, make sure that all pedestrians, including the instructor, are standing in a safe place and in view of the driver, and the undercarriage clears the curb.

1. Place three or more cones toward the back of the truck so that they will be contacted by the vehicle when it pulls away. If a curb is not available, a painted line or other simulated curb is acceptable.
2. Start with the truck close to and parallel with the curb.
3. Tell the driver to turn the wheels sharply and then start pulling away from curb.
4. Let the vehicle strike the cones.
5. Once the vehicle is away from the curb, and overhang is maximized, tell the driver to stop.
6. Tell the driver to exit the vehicle safely and properly to view the overhang.

Note: The axle-to-bumper distance on 11-ton trucks is much longer than on many other Postal Service vehicles and the overhang is more severe.

Exhibit D-2

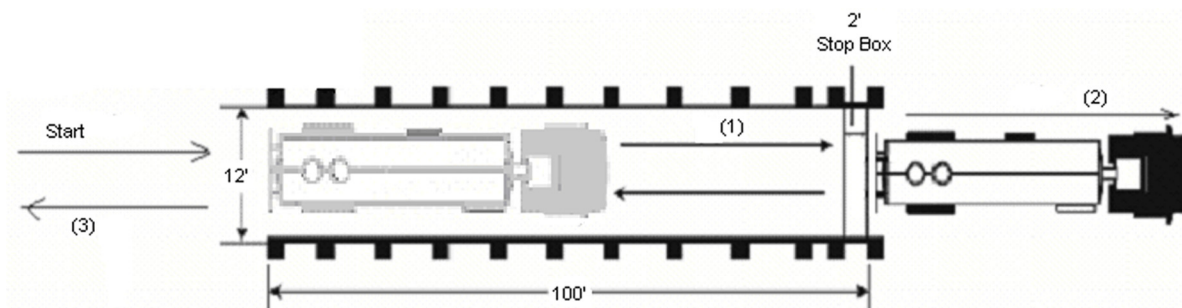
Forward, Stop, Straight-Line Backing Station

Dimensions: The width of this maneuver is vehicle width plus 2 feet.

Purpose: Driver will demonstrate the ability to stop safely and properly at designated points and to back up in a straight line. Driver is required to:

1. Pull forward and stop with the front bumper within 1 foot of a specified point;
2. Pull forward again and stop; and then
3. Back through the station in a straight line.

Certified/Not-Certified Activity: Yes.

Instructions:

Before starting this task, make sure that all pedestrians, including the instructor, are standing in a safe place and in view of the driver.

1. Begin with the truck at the Start point, ready to drive forward through the station.
2. Explain that the vehicle must be kept inside the boundary lines of the station and stop with the front bumper within the 2-foot wide Stop Box.
3. **Tell the driver to sound the horn before backing up.**
4. Signal when to start.
5. Tell the driver to:
 - a. Pull forward through the station and stop with the front bumper within the Stop Box. The driver may stop only once.
 - b. Pull straight forward until the rear bumper is beyond the Stop Box. The driver may stop only once.
 - c. Secure and exit the truck properly.
6. Signal the driver to back through the station in a straight line until the entire truck has cleared the station.

Exhibit D-3

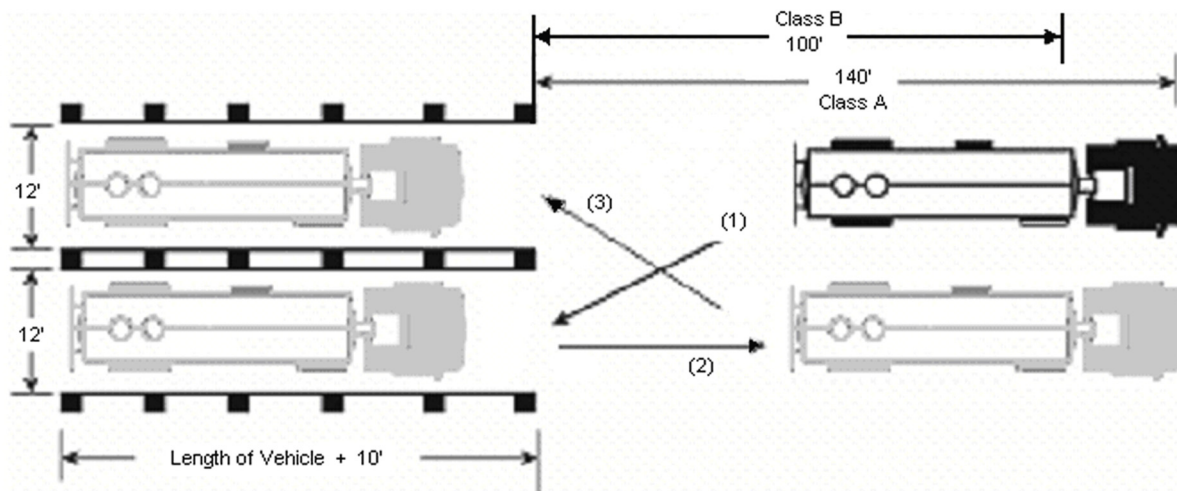
Offset Backing Station**Dimensions:**

- Length of 2-ton vehicle is 20 feet, 3 inches + 10 inches = 30 feet, 3 inches.
- Distance from cone at 30 feet 3 inches to starting point is 50 feet.
- Width of both stalls is vehicle width + 2 feet.

Purpose: Driver will demonstrate the ability to back a large truck up to a simulated dock safely and properly. The student is required to perform both right-offset-backing and left-offset-backing maneuvers.

Certified/Not-Certified Activity: Yes.

Instructions:

Before starting this task, make sure that all pedestrians, including the instructor, are standing in a safe place and in view of the driver.

1. Start with the truck at the "Class A" or "Class B" starting point.
2. Explain that the vehicle must be kept inside the boundary lines of the station.
3. **Tell the driver to sound the horn before backing up.**
4. Signal when to start.
5. Tell the driver to:
 - a. Offset back into the right stall.
 - b. Pull straight out to the start distance again.
 - c. Offset back into the left stall.
6. Then tell the driver to secure and exit the truck properly.

Note: The order of the offset maneuvers may be reversed, but the driver must complete both maneuvers properly.

Exhibit D-4
Alley and Dock Backing Station

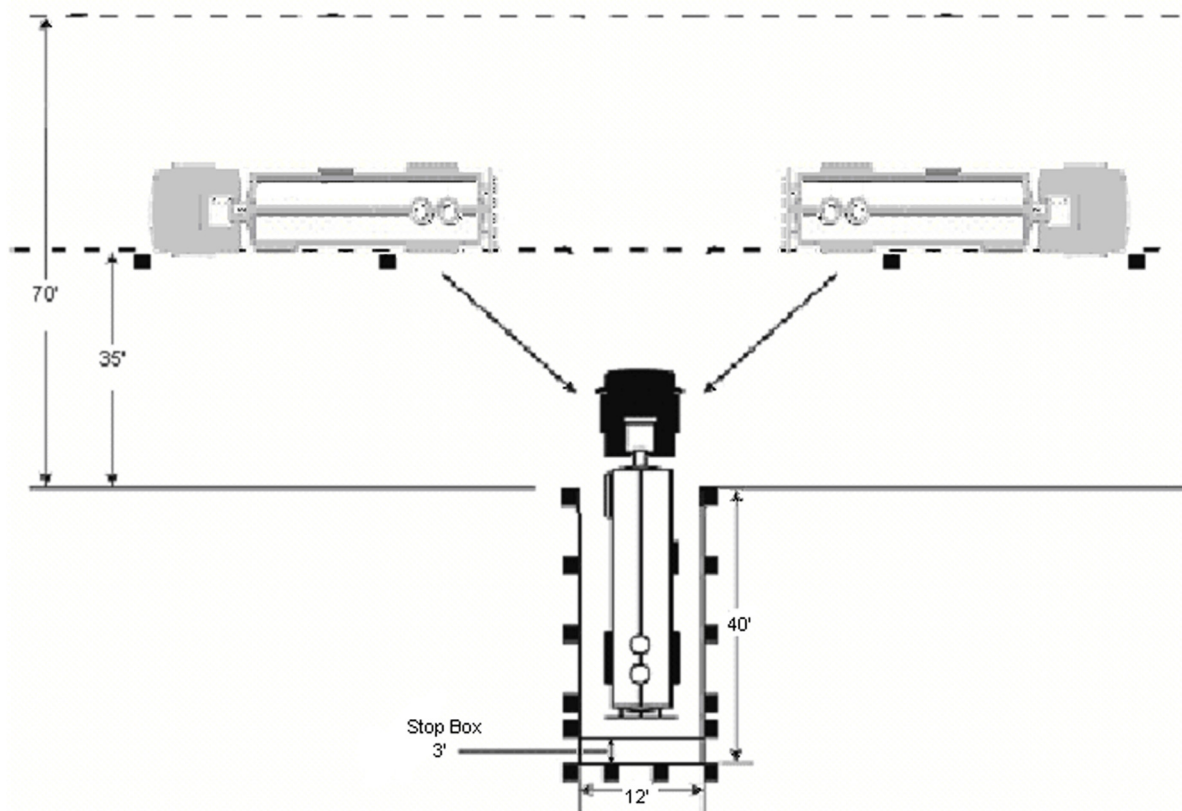

Dimensions:

- Depth of station: 20 feet.
- Change starting position to start inside of cones placed at 35 feet.

Purpose: Driver will demonstrate the ability to safely and properly back a large truck up to a simulated alley or dock from a starting point perpendicular to the alley or dock. The student is required to perform both a “sight-side” and a “blind-side” backing maneuver.

Certified/Not-Certified Activity: Yes.

Instructions:

Before starting this task, make sure that all pedestrians, including the instructor, are standing in a safe place and in view of the driver.

1. Start with the truck perpendicular to the alley or dock and parallel to cones placed in a row 35 feet in front of the space.
2. **Tell the driver to sound the horn before backing up.**
3. Signal when to start.
4. Tell the driver to:
 - a. Back into the alley or dock and stop within 3 feet of the rear cones.
 - b. Pull forward in the opposite direction.
 - c. Stop parallel to the cones.
 - d. Back into the alley or dock again.
5. Then tell the driver to secure and exit the truck properly.

Note: The order of these maneuvers does not matter; however, both sight-side and blind-side backing must be completed properly.

Exhibit D-5

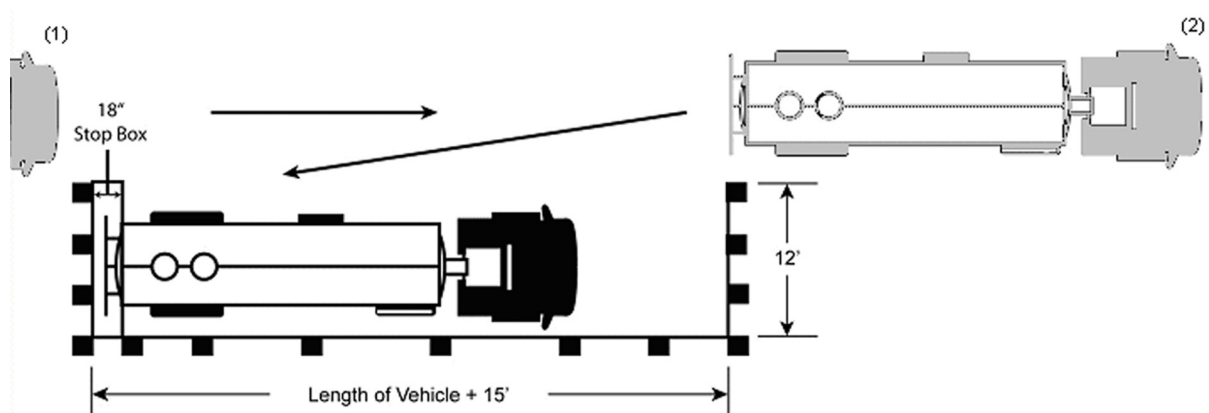
Parallel Parking Station**Dimensions:**

- Width of station is 10 feet.
- Distance from curb: use requirements of state departments of motor vehicles.

Purpose: Driver will demonstrate the ability to back into a parallel parking spot safely and properly.

Certified/Not-Certified activity: Yes.

Instructions:

Before starting this task, make sure that all pedestrians, including the instructor, are standing in a safe place and in view of the driver.

1. Explain that the vehicle must be backed into the stall and come to a stop with the rear bumper inside the 18-inch-wide Stop Box with all wheels parallel and within 3 feet of the curb.
2. Begin with the truck behind the parking stall.
3. Signal when to start.
4. Tell the driver to:
 - a. Pull forward, past the parking space.
 - b. Back into it.
5. Then tell the driver to secure and exit the truck safely and properly.

Note: The activity is successfully accomplished only if the driver is able to park properly without having to exit the vehicle to check clearances.